



# BWB15INFS

15' INFINITY STYLE  
BENCH WITH BACK  
INGROUND MOUNT DESIGN

WEBCOAT PRODUCTS  
P.O. BOX 3160  
McALESTER, OKLAHOMA 74501  
1-800-505-5101  
FAX: (918)426-5924  
E-MAIL: WEBCOAT@WEBCOAT.COM

Please take the time to locate and identify each part. Assemble the units on a smooth flat surface. It is also helpful to lay the tops and seats on cardboard or a drop cloth to prevent scratching of the surface during assembly. All parts have been pre-cut and pre-drilled for ease of assembly. All holes are slotted to allow for easy assembly and for final levelling of tops and seats to frames. Fully assemble all parts without totally tightening nuts and bolts. After all assembled go back and retighten nuts to bolts. DO NOT OVER TIGHTEN NUTS TO BOLTS. Over tightened nuts can crack the plastisol coating. All the necessary quantities of parts required are listed in this assembly instructions.

DO NOT BEGIN ASSEMBLY UNTIL YOU HAVE READ THESE INSTRUCTIONS AND ARE FAMILIAR WITH THE PARTS.



# PARTS IDENTIFICATION

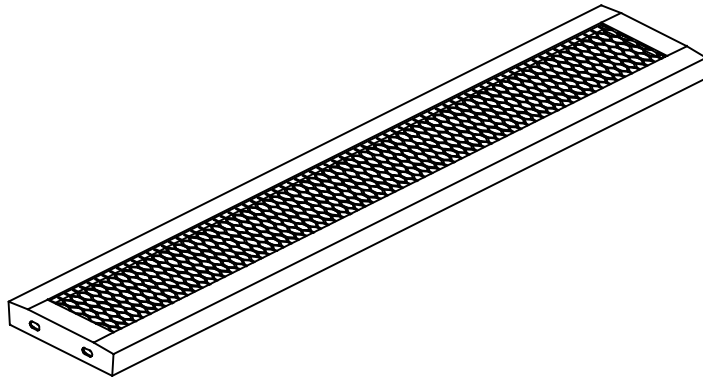

(A) 7.5' INF SEAT

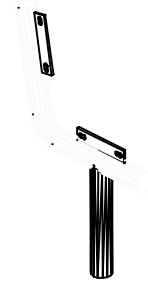

(B) BENCH FRAME

## PARTS LIST

ITEM	PART#	DESCRIPTION	QTY.
A	S7.5INF	7.5' INF SEAT	4
B	FBWBI	BENCH FRAME W/BACK	4

ITEM	HARDWARE DESCRIPTION	QTY.
HW1	5/16" X 18 NYL LOCKNUTS	20
HW2	5/16" X 18GA CAP BOLTS	20
HW3	5/16" FLAT WASHERS	40
HW4	BOLT GUARDS	20

ASSEMBLY TOOLS REQUIRED  
2- 1/2" WRENCHES

## HARDWARE IDENTIFICATION



(HW1) 5/16" X 18  
NYL LOCKNUTS



(HW2) 5/16" X 18  
GAUGE CAP BOLTS



(HW3) 5/16"  
FLAT WASHERS



(HW4) BOLT  
GUARDS

# ASSEMBLY PROCEDURES

## STEP 1

MOUNT THE SEAT BY MEANS OF EIGHT 5/16" X 1 1/2" HEXBOLTS, SIXTEEN 5/16" FLAT WASHERS AND EIGHT 5/16" NYLOCK NUTS THROUGH THE SLOTTED HOLES ON THE SEATS AND THROUGH THE SLOTTED HOLES ON ANGLE IRON OF FRAME ENDS. Hand tighten only at this time.

## STEP 2

FOLLOWING THE FOOTING DIAGRAM BELOW, DIG TWO INLINE HOLES APPROXIMATELY 24" DEEP BY 12" ROUND. THE DISTANCE BETWEEN HOLES 1 AND 2 IS 66 1/4" CENTER TO CENTER. THE DISTANCE BETWEEN HOLES 2 AND 3 IS 20 3/4" AND BETWEEN HOLES 3 AND FOUR 69 3/8".

## STEP 3

SET BENCH END FRAMES IN HOLES. MAKE SURE TOP OF SEATS ARE 18" ABOVE GROUND LEVEL AND ARE IN LINE. FILL WITH CONCRETE, LEVEL SEAT.

LET STAND 24 HOURS BEFORE COMPLETING ASSEMBLY INSTRUCTIONS.

## STEP 4

TIGHTEN ALL NUTS ON ALL BOLTS AND PLACE THE BOLT GUARDS ON ALL NUTS. DO NOT OVER TIGHTEN THE NUTS AS THIS COULD CAUSE THE PLASTISOL COATING TO CRACK.

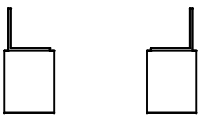

ANGLE BOLTS TO INSIDE OF BRACE, FACING EACH OTHER.

1	CAP. BOLT & WASHER
2	WASHER & LOCK NUT

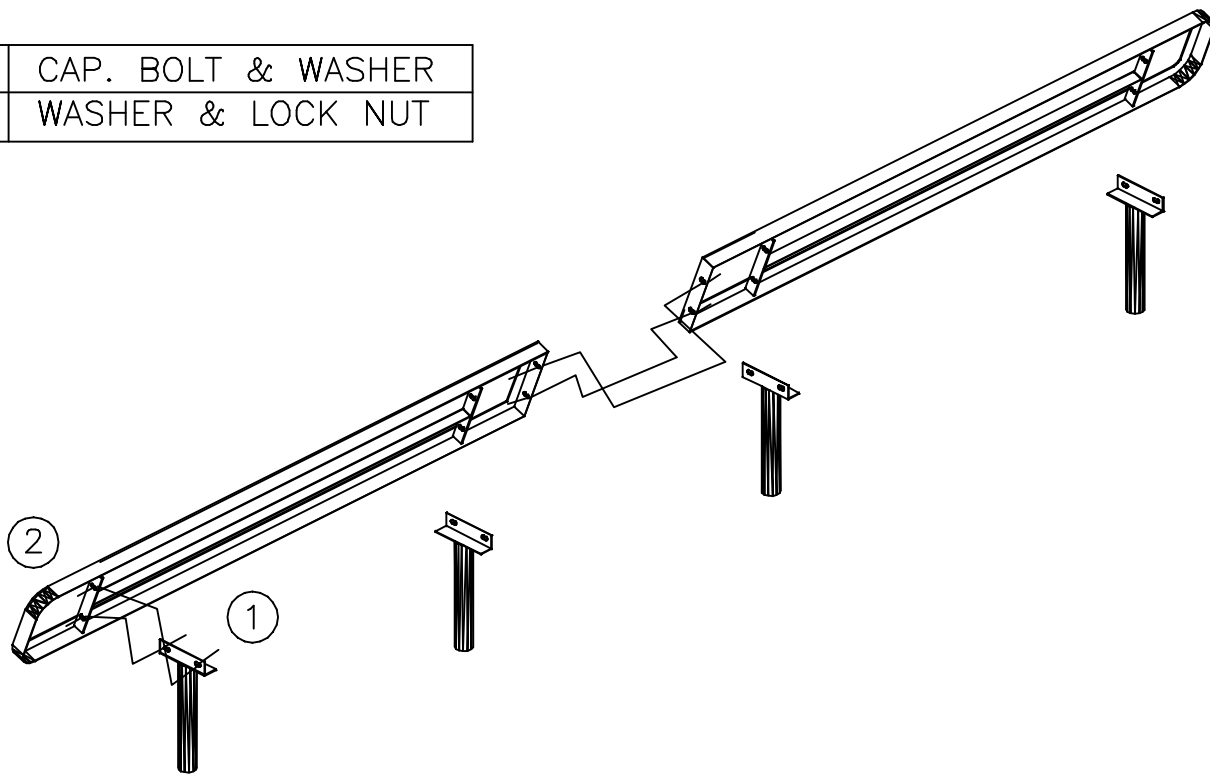

FOOTING DIAGRAM

