



# B6 MODERNS

## 6' MODERN STYLE BENCH INGROUND MOUNT DESIGN

WEBCOAT PRODUCTS  
P.O. BOX 3160  
McALESTER, OKLAHOMA 74501  
1-800-505-5101  
FAX: (918)426-5924  
E-MAIL: WEBCOAT@WEBCOAT.COM

Please take the time to locate and identify each part. Assemble the units on a smooth flat surface. It is also helpful to lay the tops and seats on cardboard or a drop cloth to prevent scratching of the surface during assembly. All parts have been pre-cut and pre-drilled for ease of assembly. All holes are slotted to allow for easy assembly and for final levelling of tops and seats to frames. Fully assemble all parts without totally tightening nuts and bolts. After all assembled go back and retighten nuts to bolts. DO NOT OVER TIGHTEN NUTS TO BOLTS. Over tightened nuts can crack the plastisol coating. All the necessary quantities of parts required are listed in this assembly instructions.

**DO NOT BEGIN ASSEMBLY UNTIL YOU HAVE READ THESE INSTRUCTIONS AND ARE FAMILIAR WITH THE PARTS.**



# PARTS IDENTIFICATION

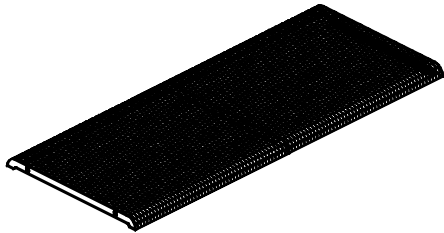

(A) 6' MODERN SEAT



(B) BENCH FRAME

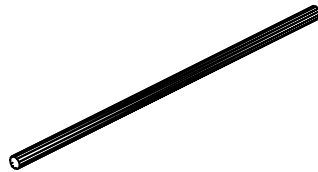

(C) CONNECTING PIPE

## PARTS LIST

ITEM	PART#	DESCRIPTION	QTY.
A	S6MODERN	6' MODERN SEAT	1
B	FB6MODI	BENCH FRAME	2
C	F4CPIPE	CONNECTING PIPE	2

ITEM	HARDWARE DESCRIPTION	QTY.
HW1	5/16" X 18 NYL LOCKNUTS	4
HW2	5/16" X 18GA CAP BOLTS	4
HW3	5/16" FLAT WASHERS	8
HW4	BOLT GUARDS	4

ASSEMBLY TOOLS REQUIRED  
2- 1/2" WRENCHES

## HARDWARE IDENTIFICATION



(HW1) 5/16" X 18  
NYL LOCKNUTS

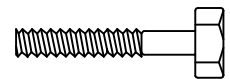

(HW2) 5/16" X 18  
GAUGE CAP BOLTS



(HW3) 5/16"  
FLAT WASHERS



(HW4) BOLT  
GUARDS

# ASSEMBLY PROCEDURES

## STEP 1

CONNECT THE TWO END FRAMES TOGETHER BY PLACING FLARED ENDS OVER THE 6" STUBS ON THE END FRAMES.

## STEP 2

SET BENCH SEAT ON FRAME WITH BENCH END BRACES ON OUTSIDE OF FRAME MOUNTING BRACKETS. FASTEN TOGETHER BY USING FOUR 1 1/2" X 5/16" BOLTS AND NUTS AND EIGHT WASHERS. HAND TIGHTEN ONLY AT THIS TIME.

## STEP 3

FOLLOWING FOOTING DIAGRAM BELOW, DIG FOUR HOLES APPROXIMATELY 20" DEEP X 12" DIA. SET BENCH IN HOLES, LEVEL AND MAKE CERTAIN TOP OF SEAT IS 16 1/2" FROM GROUND. FILL HOLES WITH CONCRETE AND LET STAND FOR 24 HOURS BEFORE USE.

## STEP 3

TIGHTEN ALL NUTS ON ALL BOLTS SECURELY.

DO NOT OVER TIGHTEN AS THIS WILL CAUSE THE PLASTISOL COATING TO CRACK.

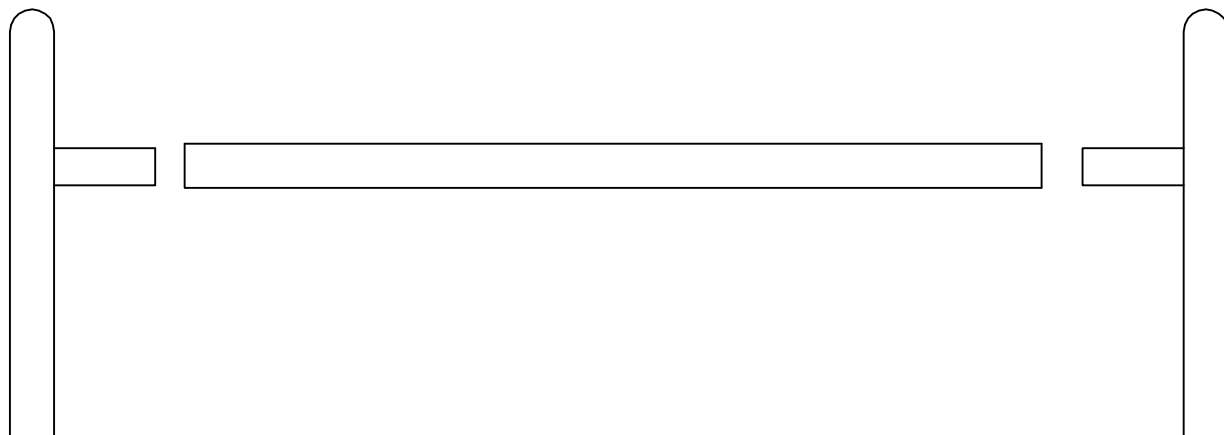
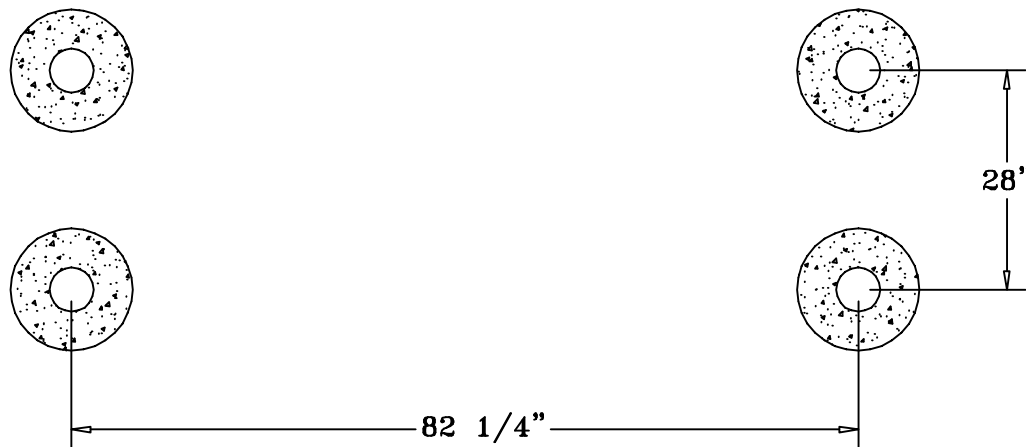

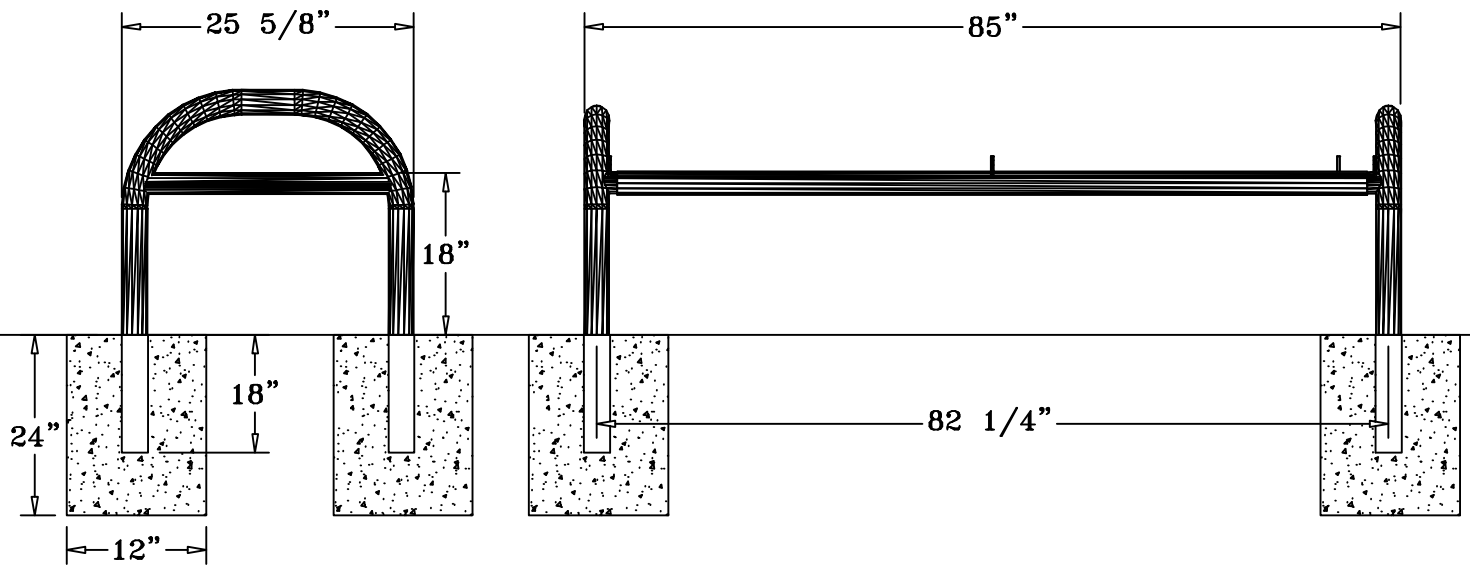

## SPECIFICATIONS

6' POLY VINYL COATED MODERN STYLE BENCH.  
 FRAME IS INGROUND MOUNT DESIGN.

COATED WITH A 1/8" TO 1/4" THICK PLASTISOL ULTRAVIOLET STABILIZED VINYL COATING  
 FUSED AND BAKED TO A 90% GLOSS.

SEAT HEIGHT IS 15" APPROXIMATELY.

TOTAL OVERALL DIMENSIONS ARE 25 5/8" X 85" APPROXIMATELY.

SEATS ARE MADE FROM 3/4" #9 EXPANDED METAL INSIDE OF A 2' x 2" x 1/8" ANGLE  
 IRON FRAME. ALL CENTER BRACES ARE MADE FROM 1/4" X 1 1/2" FLAT STEEL.

FRAMES ARE MADE OF 2 7/8" HEAVY GALVANIZED STEEL TUBING THAT IS GALVANIZED INSIDE  
 AND OUT AND MEETS OR EXCEEDS THE YIELD AND TENSILE OF SCH 40 PIPE. CONSTRUCTED  
 SO AS TO PROHIBIT RAIN WATER FROM COLLECTING AT GROUND LEVEL. COATED WITH A BAKED  
 ON POLYESTER POWDER COAT FINISH.

ALL HARDWARE IS NON-CORROSIVE.

WEIGHT FOR THE B6MODERNS IS 120 LBS.

## MAINTENANCE

To maintain luster it is recommended to wash, rinse, and dry the units after prolonged use.  
 Check for loose bolts and nuts and tighten as needed. Contact the factory for genuine  
 Webcoat part replacements if needed.