



B6WBMODCLASSPSM

**6' CLASSIC STYLE
BENCH WITH BACK
MODERN PORTABLE OR
SURFACE MOUNT DESIGN**

WEBCOAT PRODUCTS
P.O. BOX 3160
McALESTER, OKLAHOMA 74501
1-800-505-5101
FAX: (918)426-5924
E-MAIL: WEBCOAT@WEBCOAT.COM

Please take the time to locate and identify each part. Assemble the units on a smooth flat surface. It is also helpful to lay the tops and seats on cardboard or a drop cloth to prevent scratching of the surface during assembly. All parts have been pre-cut and pre-drilled for ease of assembly. All holes are slotted to allow for easy assembly and for final levelling of tops and seats to frames. Fully assemble all parts without totally tightening nuts and bolts. After all assembled go back and retighten nuts to bolts. **DO NOT OVER TIGHTEN NUTS TO BOLTS.** Over tightened nuts can crack the plastisol coating. All the necessary quantities of parts required are listed in this assembly instructions.

DO NOT BEGIN ASSEMBLY UNTIL YOU HAVE READ THESE INSTRUCTIONS AND ARE FAMILIAR WITH THE PARTS.



PARTS IDENTIFICATION

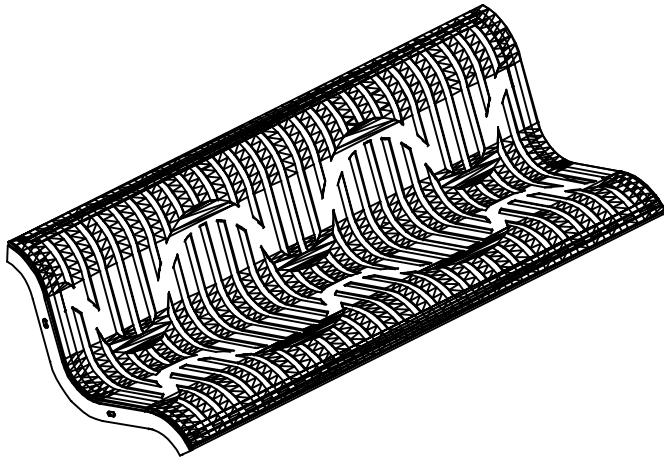

(A) 6' CLASSIC SEAT

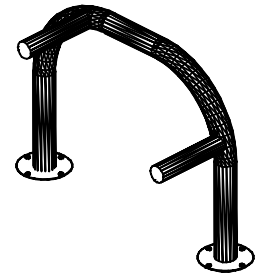

(B) MODERN FRAME

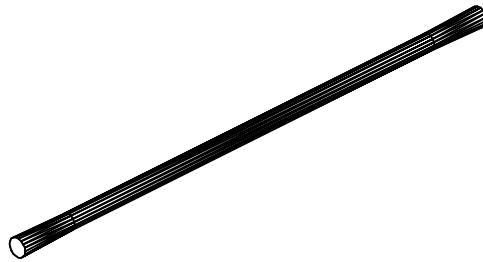

(C) CONNECTONG PIPE

PARTS LIST

ITEM	PART#	DESCRIPTION	QTY.
ITEM AFBWBMODPSM		6' CLASSIC MODERN SEAT	1
ITEMB F6CPIPE		MODERN FRAME	2
ITEMC		CONNECTING PIPE	2

S6WBCLASSMOD

ITEM	HARDWARE DESCRIPTION	QTY.
HW1	5/16" X 18 NYL LOCKNUTS	4
HW2	5/16" X 18GA CAP BOLTS	4
HW3	5/16" FLAT WASHERS	8
HW4	BOLT GUARDS	4

ASSEMBLY TOOLS REQUIRED
2- 1/2" WRENCHES

HARDWARE IDENTIFICATION



(HW1) 5/16" X 18
NYL LOCKNUTS

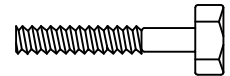

(HW2) 5/16" X 18
GAUGE CAP BOLTS



(HW3) 5/16"
FLAT WASHERS



(HW4) BOLT
GUARDS

ASSEMBLY PROCEDURES

STEP 1

SET FRAME ON LEVEL SURFACE.

STEP 2

MOUNT BENCH TO FRAME BY LINING UP THE TWO BOLTS WELDED ON THE FRAME TO THE TWO HOLES ON THE SEAT. Hand tighten only at this time.

STEP 3

NOW THAT ALL PARTS ARE ASSEMBLED, SQUARE AND ALIGN ALL PARTS OF THE UNIT THEN TIGHTEN ALL NUTS ON ALL BOLTS SECURELY.

DO NOT OVER TIGHTEN AS THIS WILL CAUSE THE PLASTISOL COATING TO CRACK.

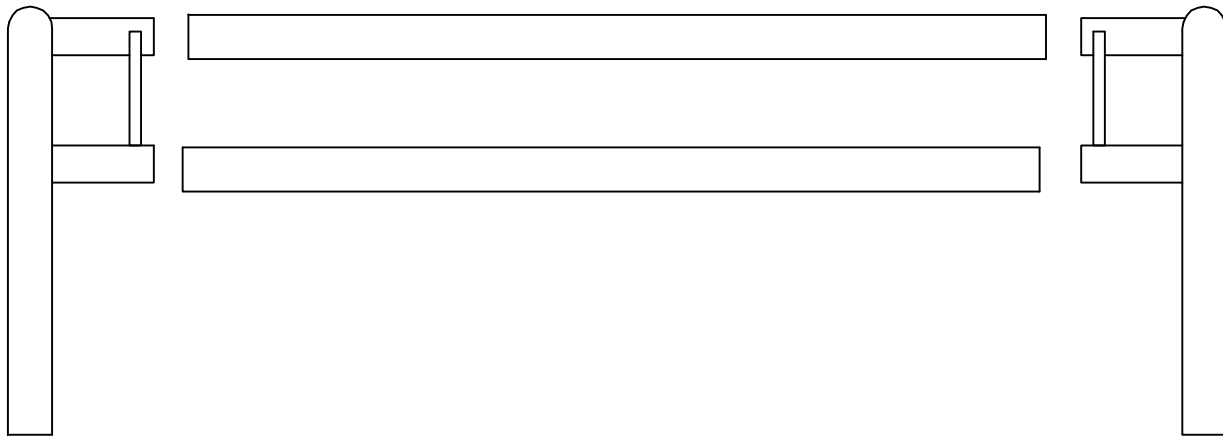

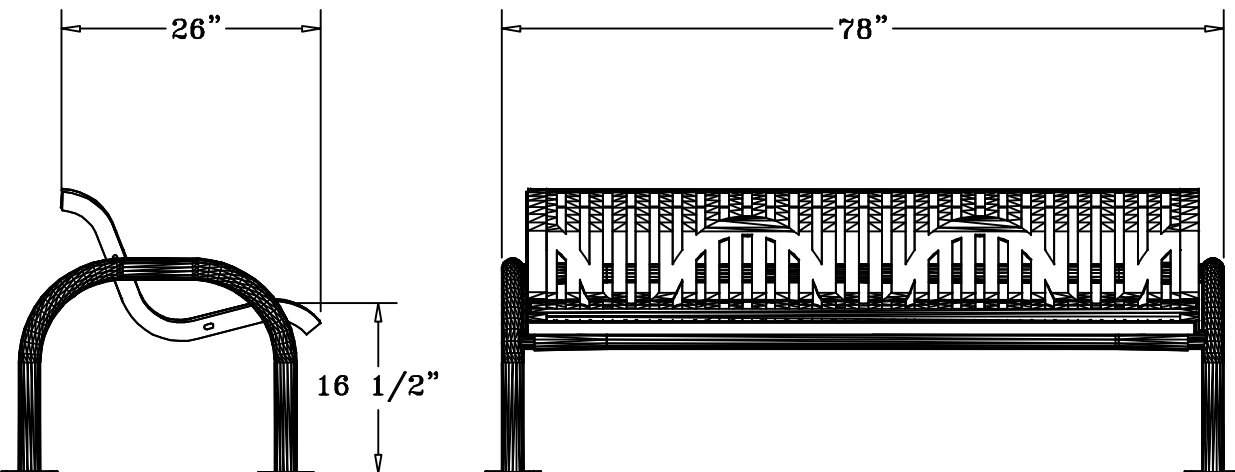

SPECIFICATIONS

6' POLY VINYL COATED CLASSIC STYLE BENCH WITH BACK.
FRAME IS PORTABLE OR SURFACE MOUNT DESIGN.

COATED WITH A 1/8" TO 1/4" THICK PLASTISOL ULTRAVIOLET STABILIZED VINYL COATING
FUSED AND BAKED TO A 90% GLOSS.

SEAT HEIGHT IS 16 1/2" APPROXIMATELY. TOTAL OVERALL DIMENSIONS ARE 78" X 26".

THE SEAT IS MADE FROM 11 GA. PLASMA CUT STEEL.

UNDER STRUCTURE IS MADE FROM HEAVY WALL TUBING IN A FOUR PIECE DESIGN, FABRICATED IN
SUCH A WAY TO CREATE ARM RESTS ON EACH END OF BENCH. UNDER FRAME IS MADE OF 3"
TUBING THAT IS GALVANIZED AND THEN COATED WITH A BAKED ON POLYESTER POWDER COAT FINISH.

ALL HARDWARE IS NON-CORROSIVE.

WEIGHT FOR THE B6WBMODCLASSPSM IS 168 LBS.

MAINTENANCE

To maintain luster it is recommended to wash, rinse, and dry the units after prolonged use.
Check for loose bolts and nuts and tighten as needed. Contact the factory for genuine
Webcoat part replacements if needed.