



# B6WBWINGLINES

**6' WINGLINE STYLE  
BENCH WITH BACK  
INGROUND MOUNT DESIGN**

WEBCOAT PRODUCTS  
P.O. BOX 3160  
McALESTER, OKLAHOMA 74501  
1-800-505-5101  
FAX: (918)426-5924  
E-MAIL: WEBCOAT@WEBCOAT.COM

Please take the time to locate and identify each part. Assemble the units on a smooth flat surface. It is also helpful to lay the tops and seats on cardboard or a drop cloth to prevent scratching of the surface during assembly. All parts have been pre-cut and pre-drilled for ease of assembly. All holes are slotted to allow for easy assembly and for final levelling of tops and seats to frames. Fully assemble all parts without totally tightening nuts and bolts. After all assembled go back and retighten nuts to bolts. **DO NOT OVER TIGHTEN NUTS TO BOLTS.** Over tightened nuts can crack the plastisol coating. All the necessary quantities of parts required are listed in this assembly instructions.

**DO NOT BEGIN ASSEMBLY UNTIL YOU HAVE READ THESE INSTRUCTIONS AND ARE FAMILIAR WITH THE PARTS.**



# PARTS IDENTIFICATION

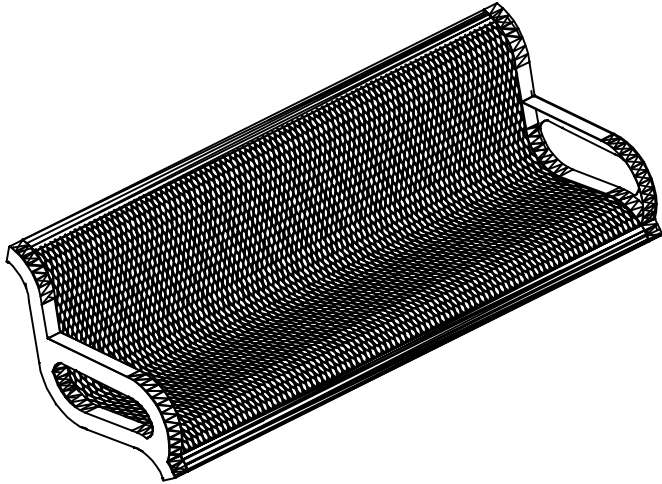

(A) 6' WINGLINE SEAT



(B) BENCH FRAME

## PARTS LIST

ITEM	PART#	DESCRIPTION	QTY.
A	S6WINGLINE	4' WINGLINE SEAT	1
B	FRAME	BENCH FRAME	2

ITEM	HARDWARE DESCRIPTION	QTY.
HW1	5/16" X 18 NYL LOCKNUTS	4
HW2	5/16" X 18GA CAP BOLTS	4
HW3	5/16" FLAT WASHERS	8
HW4	BOLT GUARDS	4

**ASSEMBLY TOOLS REQUIRED**  
2- 1/2" WRENCHES

## HARDWARE IDENTIFICATION



(HW1) 5/16" X 18  
NYL LOCKNUTS

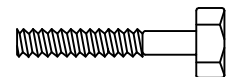

(HW2) 5/16" X 18  
GAUGE CAP BOLTS



(HW3) 5/16"  
FLAT WASHERS



(HW4) BOLT  
GUARDS

# ASSEMBLY PROCEDURES

## STEP 1

MOUNT SEAT TO FRAMES AS SHOWN BELOW BY MEANS OF FOUR 5/16" BOLTS, EIGHT FLAT WASHERS AND FOUR NUTS, THROUGH THE SLOTTED HOLES IN THE SEAT END PLATES AND THE SLOTTED HOLES ON BOTH ENDS OF THE FRAME.

## STEP 2

FOLLOWING THE FOOTING DIAGRAM BELOW, DIG TWO INLINE HOLES APPROXIMATELY 24" DEEP BY 12" ROUND. THE DISTANCE BETWEEN HOLES 1 AND 2 IS 64 1/2" CENTER TO CENTER.

## STEP 3

SET BENCH END FRAMES IN HOLES. MAKE SURE TOP OF SEATS ARE 18" ABOVE GROUND LEVEL AND ARE IN LINE. FILL WITH CONCRETE, LEVEL SEAT.

**LET STAND 24 HOURS BEFORE COMPLETING ASSEMBLY INSTRUCTIONS.**

## STEP 4

TIGHTEN ALL NUTS ON ALL BOLTS AND PLACE THE BOLT GUARDS ON ALL NUTS.

**OVER TIGHTEN THE NUTS AS THIS COULD CAUSE THE PLASTISOL COATING TO CRACK.**

1	CAP. BOLT & WASHER
2	WASHER & LOCK NUT



FOOTING DIAGRAM

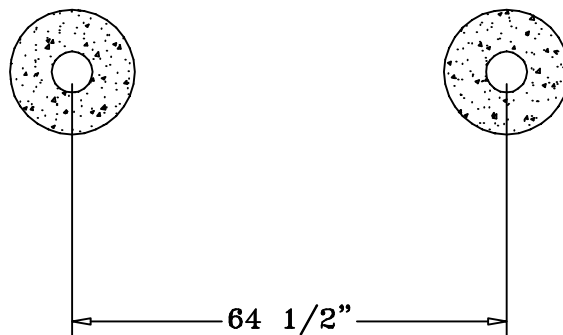

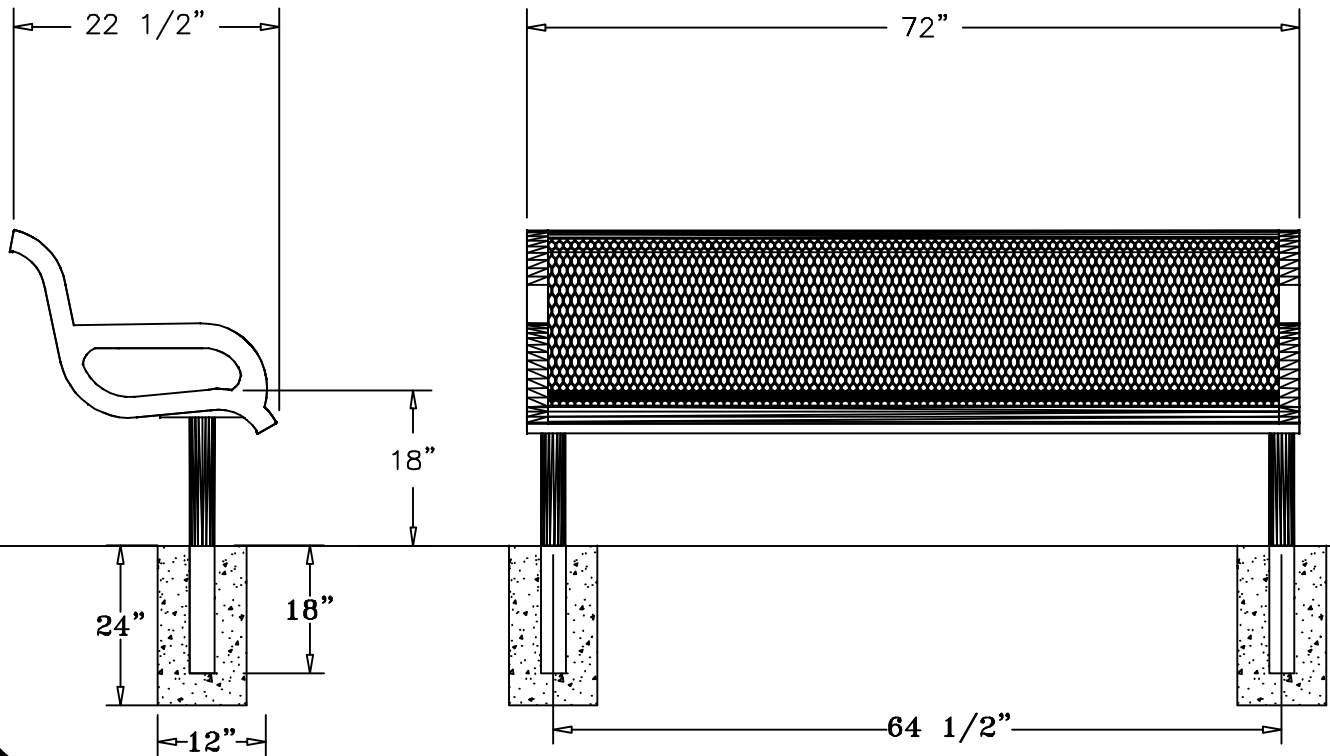

## SPECIFICATIONS

6' POLY VINYL FORMED BENCH WITH BACK.  
FRAME IS INGROUND MOUNT DESIGN.

COATED WITH A 1/8" TO 1/4" THICK PLASTISOL ULTRAVIOLET STABILIZED VINYL COATING FUSED AND BAKED TO A 90% GLOSS.

SEAT HEIGHT IS 18" APPROXIMATELY. BACK HEIGHT IS 31" APPROXIMATELY.  
TOTAL OVERALL DIMENSIONS ARE 72" X 22 1/2" APPROXIMATELY.

SEATS ARE MADE FROM 3/4" #9 EXPANDED METAL INSIDE OF A 2" X 2" X 1/8" ANGLE  
ALL CENTER BRACES ARE MADE OF 11 GAUGE FLAT STEEL.

FRAME IS MADE OF 2 7/8" TUBING.  
POWDER COATED WITH POLYESTER ELECTROSTATIC PAINT.

ALL HARDWARE IS NON-CORROSIVE.  
WEIGHT FOR THE B6WBWINGLINES IS 93 LBS.

## MAINTENANCE

To maintain luster it is recommended to wash, rinse, and dry the units after prolonged use. Check for loose bolts and nuts and tighten as needed. Contact the factory for genuine Webcoat part replacements if needed.