



# BDTCLASSCVXSM

**3 SEAT 15° CLASSIC STYLE  
DOWNTOWN CONVEX BENCH  
SURFACE MOUNT DESIGN**

WEBCOAT PRODUCTS  
P.O. BOX 3160  
McALESTER, OKLAHOMA 74501  
1-800-505-5101  
FAX: (918)426-5924  
E-MAIL: WEBCOAT@WEBCOAT.COM

Please take the time to locate and identify each part. Assemble the units on a smooth flat surface. It is also helpful to lay the tops and seats on cardboard or a drop cloth to prevent scratching of the surface during assembly. All parts have been pre-cut and pre-drilled for ease of assembly. All holes are slotted to allow for easy assembly and for final levelling of tops and seats to frames. Fully assemble all parts without totally tightening nuts and bolts. After all assembled go back and retighten nuts to bolts. DO NOT OVER TIGHTEN NUTS TO BOLTS. Over tightened nuts can crack the plastisol coating. All the necessary quantities of parts required are listed in this assembly instructions.

**DO NOT BEGIN ASSEMBLY UNTIL YOU HAVE READ THESE INSTRUCTIONS AND ARE FAMILIAR WITH THE PARTS.**



# PARTS IDENTIFICATION

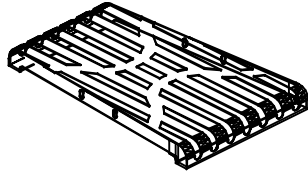

(A) CONVEX/CONCAVE SEAT

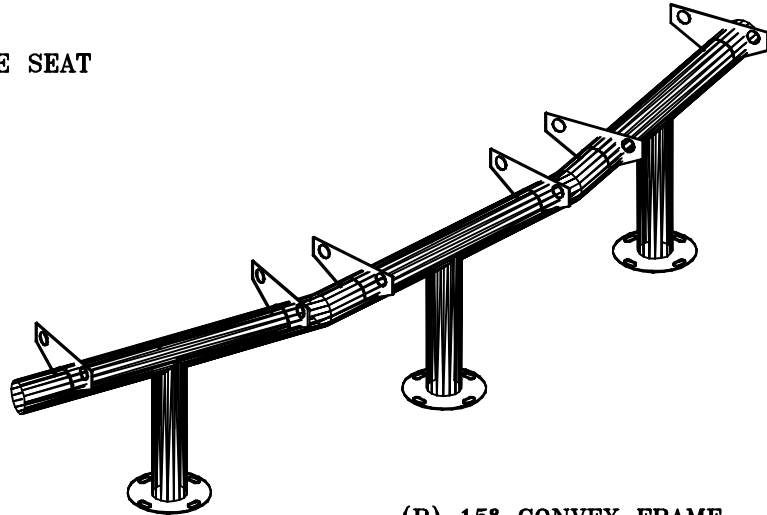

(B) 15° CONVEX FRAME

## PARTS LIST

ITEM	PART#	DESCRIPTION	QTY.
A	SCONVEX	CONVEX/CONCAVE SEAT	3
B	FCONVEX15SM	15° CONVEX FRAME	1

ITEM	HARDWARE DESCRIPTION	QTY.
HW1	5/16" X 18 NYL LOCKNUTS	12
HW2	5/16" X 18GA CAP BOLTS	12
HW3	5/16" FLAT WASHERS	24
HW4	BOLT GUARDS	12

ASSEMBLY TOOLS REQUIRED  
2- 1/2" WRENCHES

## HARDWARE IDENTIFICATION



(HW1) 5/16" X 18  
NYL LOCKNUTS



(HW2) 5/16" X 18  
GAUGE CAP BOLTS



(HW3) 5/16"  
FLAT WASHERS



(HW4) BOLT  
GUARDS

# ASSEMBLY PROCEDURES

## STEP 1

FOLLOWING FOOTING DIAGRAM BELOW, MOUNT FRAME TO SMOOTH LEVEL SURFACE.  
SURFACE MOUNTING HARDWARE NOT INCLUDED.

## STEP 2

MOUNT THE COATED FORMED SEAT TO THE FRAME BY MEANS OF TWELVE 5/16" X 1 1/2" HEXBOLTS, TWENTY-FOUR 5/16" FLAT WASHERS, AND TWELVE NYLOCK NUTS THROUGH THE SLOTTED HOLES ON THE FRAME AND THROUGH THE SLOTTED HOLES ON THE SEATS.

## STEP 3

TIGHTEN ALL NUTS ON ALL BOLTS AND PLACE THE BOLT GUARDS ON ALL NUTS. DO NOT OVER TIGHTEN THE NUTS AS THIS COULD CAUSE THE PLASTISOL COATING TO CRACK.

FOOTING DETAIL:

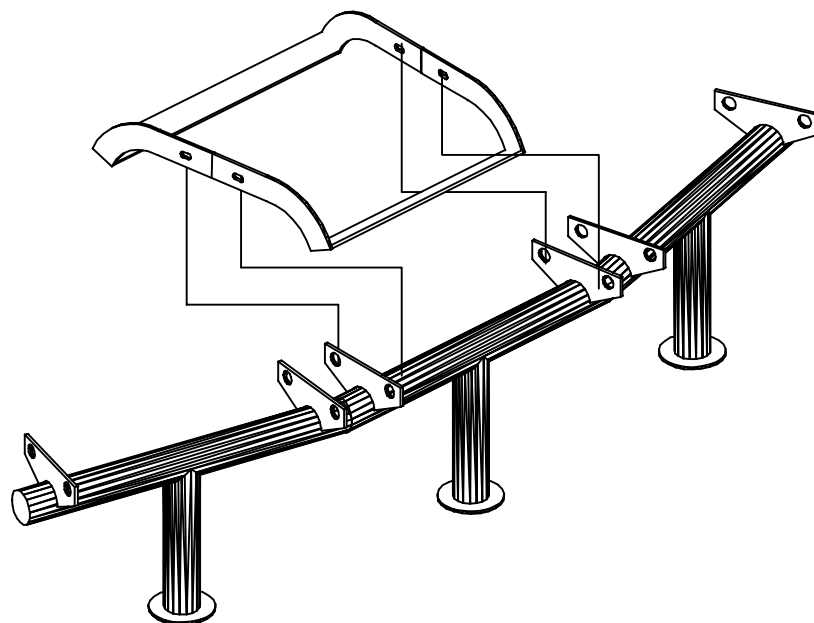
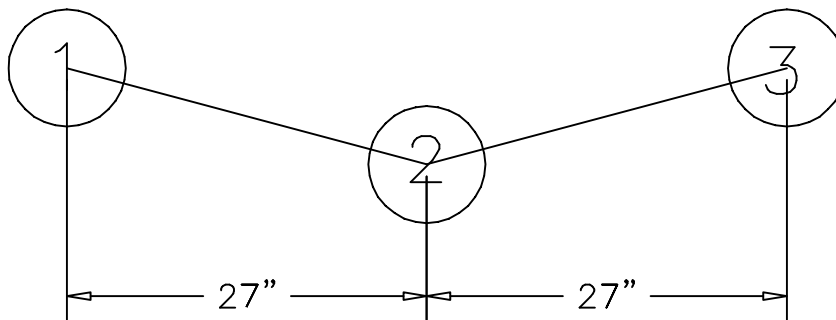

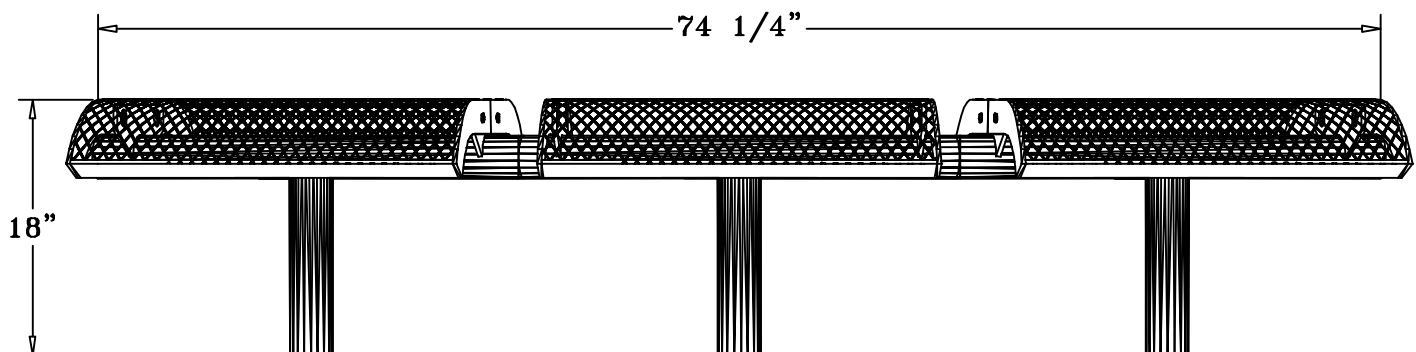

## SPECIFICATIONS

15 DEGREE CONVEX SEATS, THREE SEAT UNIT WITHOUT BACK.  
THE FRAME IS SURFACE MOUNT DESIGN.

COATED WITH A 1/8" TO 1/4" THICK PLASTISOL ULTRAVIOLET STABILIZED VINYL COATING FUSED  
AND BAKED TO A 90% GLOSS.

SEAT HEIGHT IS 17". OVERALL WIDTH IS 34 1/2". OVERALL LENGTH IS 74 1/4".

SEATS ARE MADE FROM HEAVY DUTY 3/4" #9 EXPANDED METAL. ALL CENTER BRACES ARE  
MADE FROM 1 1/4" X 3/8" FLAT STEEL.

FRAME IS A 3" 12 GAUGE HEAVY WALL ROUND TUBING THAT IS FABRICATED THEN  
POWDER COATED WITH POLYESTER BLACK ELECTROSTATIC PAINT.

ALL HARDWARE IS NON-CORROSIVE.  
WEIGHT FOR THE BDTCVX15SM IS 130 LBS.

## MAINTENANCE

To maintain luster it is recommended to wash, rinse, and dry the units after prolonged use.  
Check for loose bolts and nuts and tighten as needed. Contact the factory for genuine  
Webcoat part replacements if needed.