



BDTCLASSSS3S

3 SEAT DOWNTOWN STYLE
CLASSIC BENCH
INGROUND MOUNT DESIGN

WEBCOAT PRODUCTS
P.O. BOX 3160
McALESTER, OKLAHOMA 74501
1-800-505-5101
FAX: (918)426-5924
E-MAIL: WEBCOAT@WEBCOAT.COM

Please take the time to locate and identify each part. Assemble the units on a smooth flat surface. It is also helpful to lay the tops and seats on cardboard or a drop cloth to prevent scratching of the surface during assembly. All parts have been pre-cut and pre-drilled for ease of assembly. All holes are slotted to allow for easy assembly and for final levelling of tops and seats to frames. Fully assemble all parts without totally tightening nuts and bolts. After all assembled go back and retighten nuts to bolts. DO NOT OVER TIGHTEN NUTS TO BOLTS. Over tightened nuts can crack the plastisol coating. All the necessary quantities of parts required are listed in this assembly instructions.

DO NOT BEGIN ASSEMBLY UNTIL YOU HAVE READ THESE INSTRUCTIONS AND ARE FAMILIAR WITH THE PARTS.



PARTS IDENTIFICATION

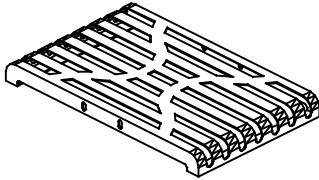

(A) SLINE DT CLASSIC SEAT

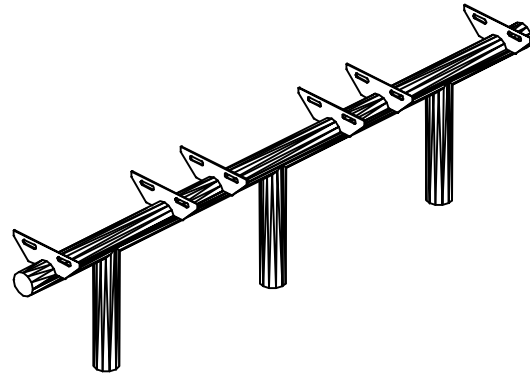

(B) SLINE FRAME

PARTS LIST

ITEM	PART#	DESCRIPTION	QTY.
A	SDTSCLAS	SLINE CLASSIC SEAT	3
B	FDTSSING	SLINE FRAME	1

ITEM	HARDWARE DESCRIPTION	QTY.
HW1	5/16" X 18 NYL LOCKNUTS	12
HW2	5/16" X 18GA CAP BOLTS	12
HW3	5/16" FLAT WASHERS	24
HW4	BOLT GUARDS	12

ASSEMBLY TOOLS REQUIRED
2- 1/2" WRENCHES

HARDWARE IDENTIFICATION



(HW1) 5/16" X 18
NYL LOCKNUTS

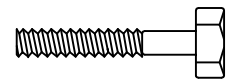

(HW2) 5/16" X 18
GAUGE CAP BOLTS



(HW3) 5/16"
FLAT WASHERS



(HW4) BOLT
GUARDS

ASSEMBLY PROCEDURES

STEP 1

FOLLOWING THE FOOTING DIAGRAM BELOW, DIG THREE HOLES APPROXIMATELY 24" DEEP BY 12" ROUND, DISTANCE BETWEEN HOLES IS 25 1/4" APPROXIMATELY, CENTER TO CENTER.

STEP 2

SET THE BENCH END FRAMES IN HOLES ON THE SAME CENTER DISTANCE AS THE HOLES. MAKE SURE THE BENCH FRAMES ARE 18" ABOVE GROUND LEVEL AND ARE IN LINE. PLUMB THE FRAMES AND FILL WITH CONCRETE.

LET STAND FOR 24 HOURS BEFORE COMPLETING THESE ASSEMBLY INSTRUCTIONS.

STEP 3

MOUNT THE COATED FORMED SEAT TO THE FRAME BY MEANS OF FOUR 5/16" X 1 1/2" HEXBOLTS, EIGHT 5/16" FLAT WASHERS, AND FOUR NYLOCK NUTS PER SEAT THROUGH THE SLOTTED HOLES ON THE FRAME AND THROUGH THE SLOTTED HOLES ON THE SEATS.

STEP 4

TIGHTEN ALL NUTS ON ALL BOLTS AND PLACE THE BOLT GUARDS ON ALL NUTS. **DO NOT OVER TIGHTEN THE NUTS AS THIS COULD CAUSE THE PLASTISOL COATING TO CRACK.**

FOOTING DETAIL:

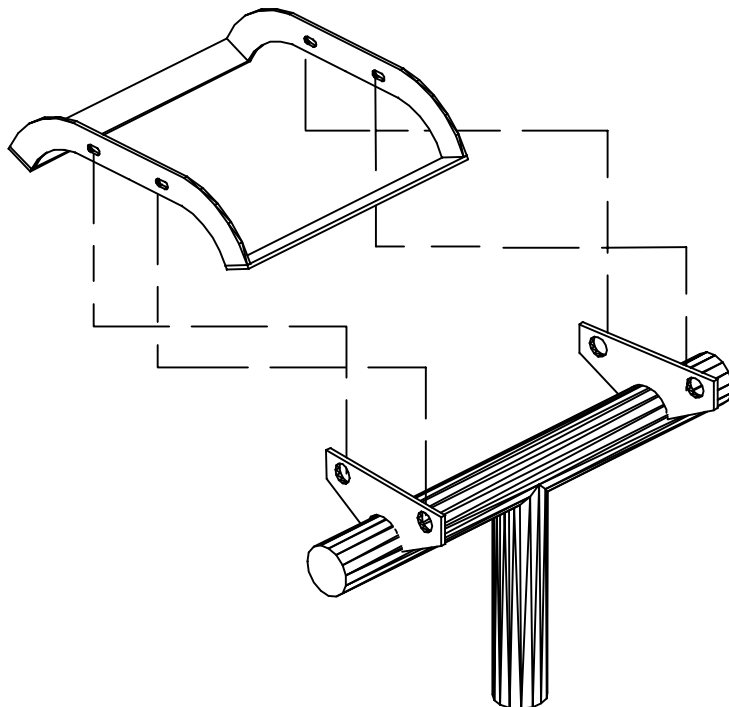
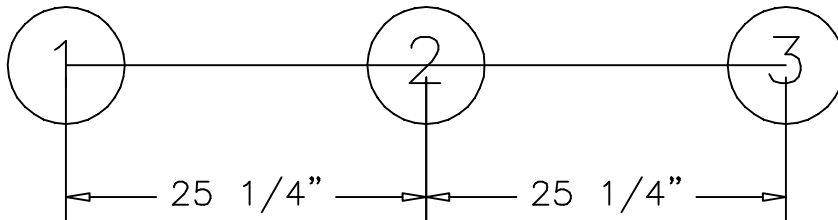

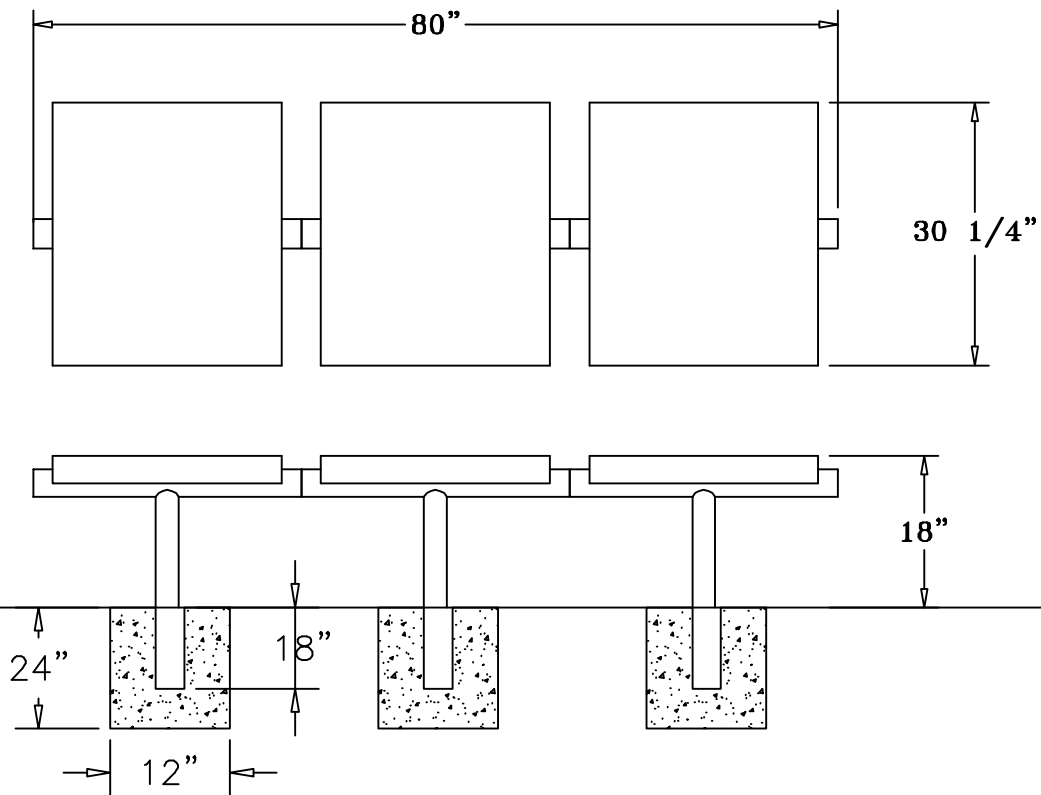

SPECIFICATIONS

3 SEAT POLY VINYL COATED RIBBED STEEL DOWNTOWN STYLE BENCH.
THE FRAME IS INGROUND MOUNT DESIGN.

COATED WITH A 1/8" TO 1/4" THICK PLASTISOL ULTRAVIOLET STABILIZED VINYL COATING
FUSED AND BAKED TO A 90% GLOSS

SEAT HEIGHT IS 18" APPROXIMATELY. OVERALL DIMENSIONS ARE 80" X 30 1/4".

SEAT IS MADE FROM 11GA. SOLID CUT OUT METAL. END BRACES ARE
MADE FROM 1 1/4" X 1/8" FLAT STEEL.

FRAME IS A 2 7/8" HEAVY DUTY GALVANIZED STEEL TUBING THAT IS GALVANIZED INSIDE
AND OUT AND MEETS OR EXCEEDS THE YIELD AND TENSIAL OF SCH 40 PIPE. CONSTRUCTED SO AS
TO PROHIBIT RAIN WATER FROM COLLECTING AT GROUND LEVEL. COATED WITH A BAKED ON
POLYESTER POWDER COAT FINISH.

ALL HARDWARE IS NON-CORROSIVE.
WEIGHT FOR THE BDT3CLASSSS3S IS 136 LBS.

MAINTENANCE

To maintain luster it is recommended to wash, rinse, and dry the units after prolonged use.
Check for loose bolts and nuts and tighten as needed. Contact the factory for genuine
Webcoat part replacements if needed.