



# BWBDTCCVS

**3 SEAT DOWNTOWN STYLE  
CONCAVE BENCH WITH BACK  
INGROUND MOUNT DESIGN**

WEBCOAT PRODUCTS  
P.O. BOX 3160  
McALESTER, OKLAHOMA 74501  
1-800-505-5101  
FAX: (918)426-5924  
E-MAIL: WEBCOAT@WEBCOAT.COM

Please take the time to locate and identify each part. Assemble the units on a smooth flat surface. It is also helpful to lay the tops and seats on cardboard or a drop cloth to prevent scratching of the surface during assembly. All parts have been pre-cut and pre-drilled for ease of assembly. All holes are slotted to allow for easy assembly and for final levelling of tops and seats to frames. Fully assemble all parts without totally tightening nuts and bolts. After all assembled go back and retighten nuts to bolts. DO NOT OVER TIGHTEN NUTS TO BOLTS. Over tightened nuts can crack the plastisol coating. All the necessary quantities of parts required are listed in this assembly instructions.

**DO NOT BEGIN ASSEMBLY UNTIL YOU  
HAVE READ THESE INSTRUCTIONS AND  
ARE FAMILIAR WITH THE PARTS.**



# PARTS IDENTIFICATION

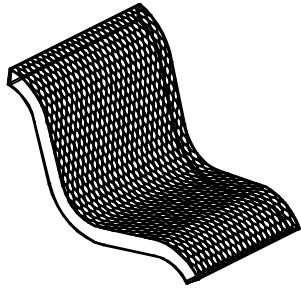

(A) CONCAVE SEAT

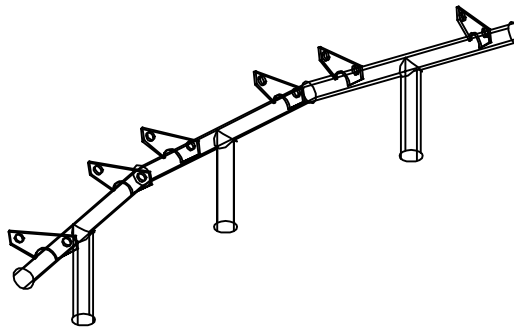

(B) CONVEX FRAME

## PARTS LIST

ITEM	PART#	DESCRIPTION	QTY.
A	SWBDTCV	CONVEX SEAT	3
B	FBWBDTCVING	3 SEAT CONVEX FRAME	1

ITEM	HARDWARE DESCRIPTION	QTY.
HW1	5/16" X 18 NYL LOCKNUTS	12
HW2	5/16" X 18GA CAP BOLTS	12
HW3	5/16" FLAT WASHERS	24
HW4	BOLT GUARDS	12

ASSEMBLY TOOLS REQUIRED  
2- 1/2" WRENCHES

## HARDWARE IDENTIFICATION



(HW1) 5/16" X 18  
NYL LOCKNUTS



(HW2) 5/16" X 18  
GAUGE CAP BOLTS



(HW3) 5/16"  
FLAT WASHERS



(HW4) BOLT  
GUARDS

# ASSEMBLY PROCEDURES

## STEP 1

FOLLOWING THE FOOTING DIAGRAM BELOW, DIG THREE HOLES APPROXIMATELY 24" DEEP BY 12" ROUND, DISTANCE BETWEEN HOLES IS 27" APPROXIMATELY, CENTER TO CENTER.

## STEP 2

SET THE BENCH END FRAMES IN HOLES ON THE SAME CENTER DISTANCE AS THE HOLES. MAKE SURE THE BENCH FRAMES ARE 18" ABOVE GROUND LEVEL AND ARE IN LINE. PLUMB THE FRAMES AND FILL WITH CONCRETE.

**LET STAND FOR 24 HOURS BEFORE COMPLETING THESE ASSEMBLY INSTRUCTIONS.**

## STEP 3

MOUNT THE COATED FORMED SEAT TO THE FRAME BY MEANS OF TWELVE 5/16" X 1 1/2" HEXBOLTS, TWENTY-FOUR 5/16" FLAT WASHERS, AND TWELVE NYLOCK NUTS THROUGH THE SLOTTED HOLES ON THE FRAME AND THROUGH THE SLOTTED HOLES ON THE SEATS.

## STEP 4

**DO NOT**

TIGHTEN ALL NUTS ON ALL BOLTS AND PLACE THE BOLT GUARDS ON ALL NUTS.

**OVER TIGHTEN THE NUTS AS THIS COULD CAUSE THE PLASTISOL COATING TO CRACK.**

FOOTING DETAIL:

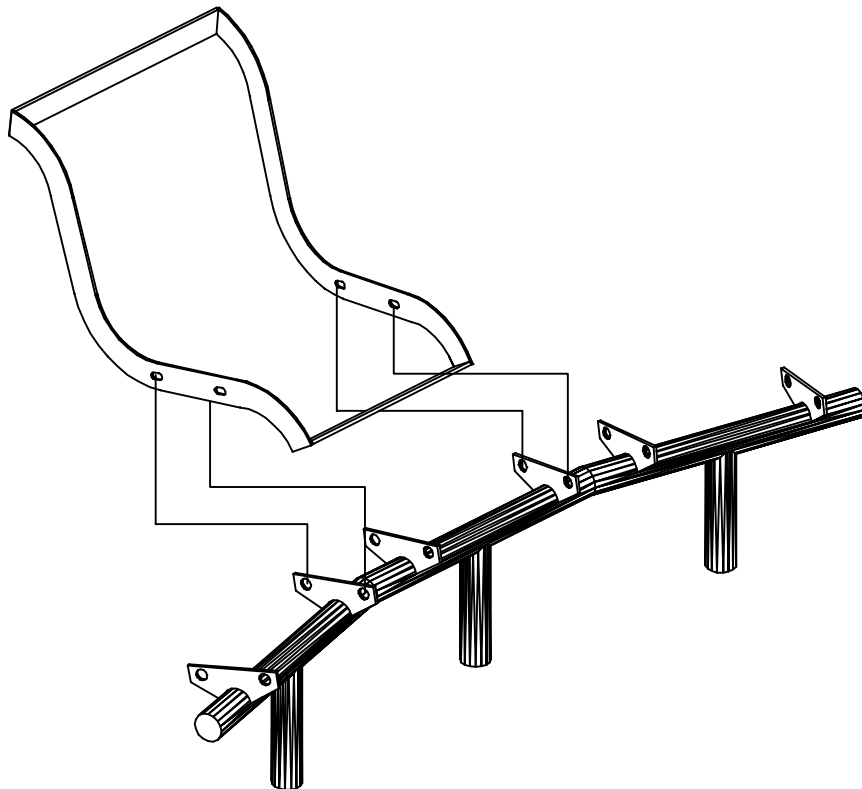
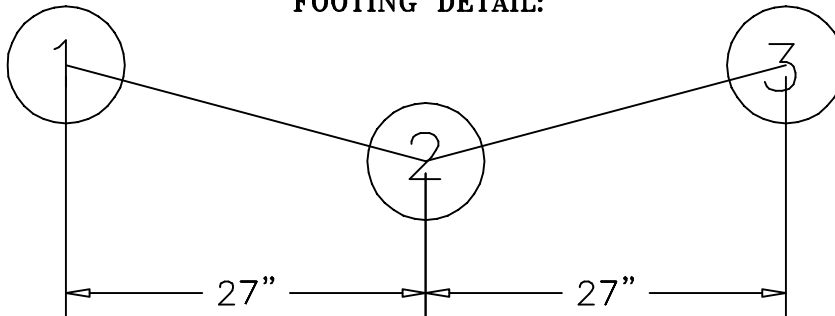

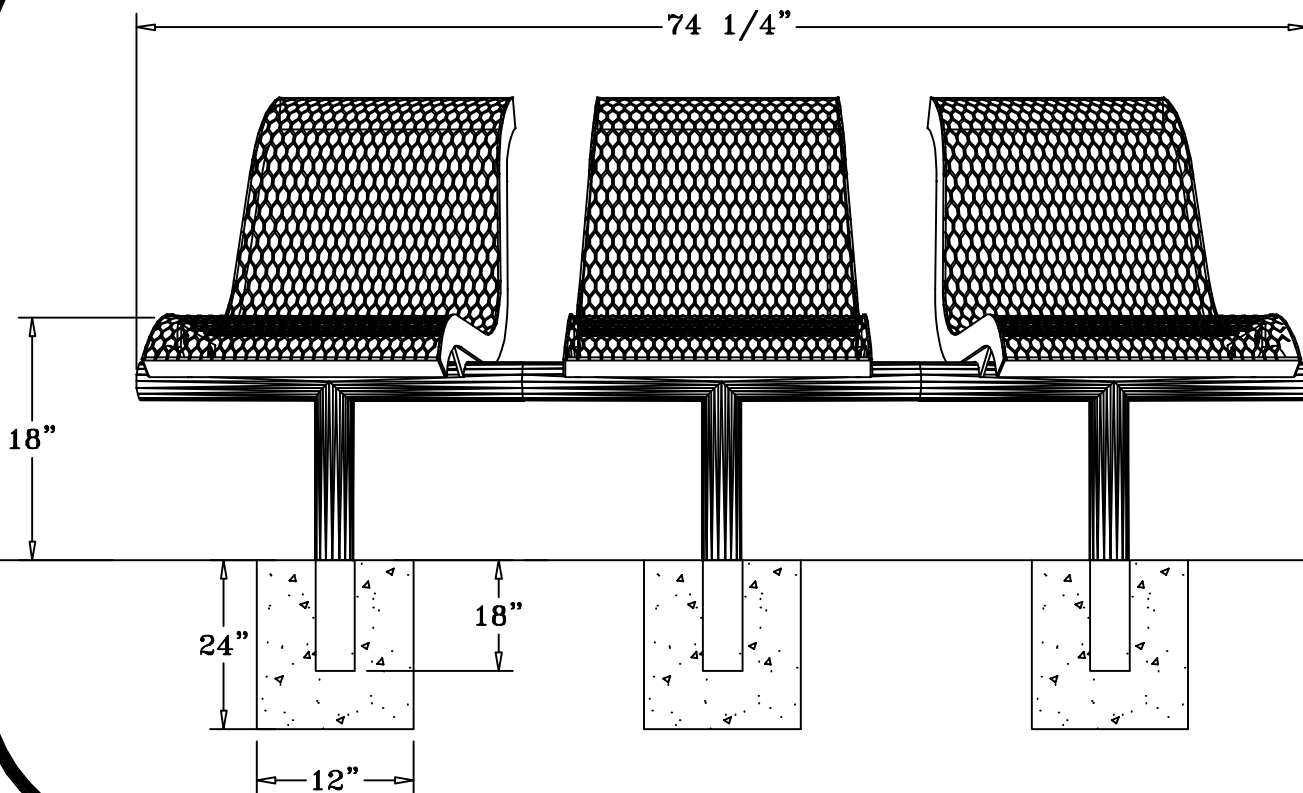

## SPECIFICATIONS

THREE SEAT CONVCAVE EXPANDED METAL UNIT WITH BACK.  
THE FRAME IS INGROUND MOUNT DESIGN.

COATED WITH A 1/8" TO 1/4" THICK PLASTISOL ULTRAVIOLET STABILIZED VINYL  
COATING FUSED AND BAKED TO A 90% GLOSS.

SEAT HEIGHT IS 18". OVERALL WIDTH IS 34 1/2". OVERALL LENGTH IS 74 1/4".

SEATS ARE MADE FROM HEAVY DUTY 3/4" #9 EXPANDED METAL. ALL CENTER BRACES  
ARE MADE FROM 1 1/4" X 3/8" FLAT STEEL.

FRAMES ARE MADE OF 2 7/8" HEAVY GALVANIZED STEEL TUBING THAT IS GALVANIZED  
INSIDE AND OUT AND MEETS OR EXCEEDS YIELD AND TENSILE OF SCH. 40 PIPE.  
CONSTRUCTED SO AS TO PROHIBIT RAIN WATER FROM COLLECTING AT GROUND LEVEL.  
COATED WITH A BAKED ON POLYESTER POWDER COAT FINISH.

ALL HARDWARE IS NON-CORROSIVE.  
WEIGHT FOR THE BWBdTCCVS IS 158 LBS.

## MAINTENANCE

To maintain luster it is recommended to wash, rinse, and dry the units after prolonged use.  
Check for loose bolts and nuts and tighten as needed. Contact the factory for genuine  
Webcoat part replacements if needed.