



BWBDTCLASSSS3S

3 SEAT CLASSIC STYLE
DOWNTOWN BENCH WITH BACK
INGROUND MOUNT DESIGN

WEBCOAT PRODUCTS
P.O. BOX 3160
McALESTER, OKLAHOMA 74501
1-800-505-5101
FAX: (918)426-5924
E-MAIL: WEBCOAT@WEBCOAT.COM

Please take the time to locate and identify each part. Assemble the units on a smooth flat surface. It is also helpful to lay the tops and seats on cardboard or a drop cloth to prevent scratching of the surface during assembly. All parts have been pre-cut and pre-drilled for ease of assembly. All holes are slotted to allow for easy assembly and for final levelling of tops and seats to frames. Fully assemble all parts without totally tightening nuts and bolts. After all assembled go back and retighten nuts to bolts. **DO NOT OVER TIGHTEN NUTS TO BOLTS.** Over tightened nuts can crack the plastisol coating. All the necessary quantities of parts required are listed in this assembly instructions.

DO NOT BEGIN ASSEMBLY UNTIL YOU HAVE READ THESE INSTRUCTIONS AND ARE FAMILIAR WITH THE PARTS.



PARTS IDENTIFICATION

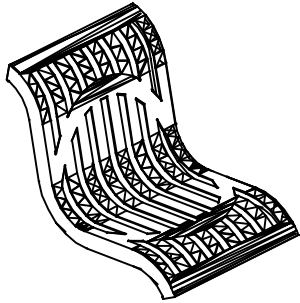

(A) SLINE DT SEAT

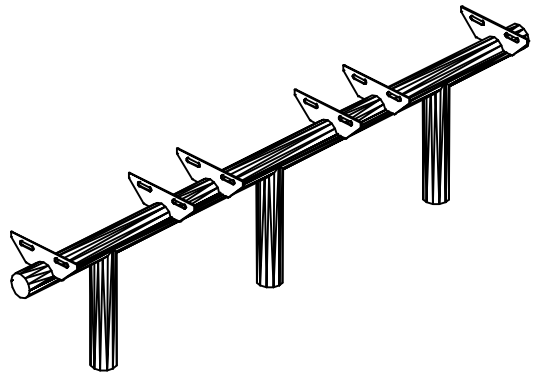

(B) SLINE FRAME

PARTS LIST

| ITEM | PART# | DESCRIPTION | QTY. |
|------|--------------|--------------------|------|
| A | SWBDTSCCLASS | SLINE CLASSIC SEAT | 3 |
| B | FBWBBDTNG | SLINE FRAME-3 | 1 |

| ITEM | HARDWARE DESCRIPTION | QTY. |
|------|-------------------------|------|
| HW1 | 5/16" X 18 NYL LOCKNUTS | 12 |
| HW2 | 5/16" X 18GA CAP BOLTS | 12 |
| HW3 | 5/16" FLAT WASHERS | 24 |
| HW4 | BOLT GUARDS | 12 |

ASSEMBLY TOOLS REQUIRED
2- 1/2" WRENCHES

HARDWARE IDENTIFICATION



(HW1) 5/16" X 18
NYL LOCKNUTS

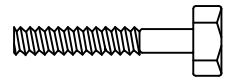

(HW2) 5/16" X 18
GAUGE CAP BOLTS



(HW3) 5/16"
FLAT WASHERS



(HW4) BOLT
GUARDS

ASSEMBLY PROCEDURES

STEP 1

FOLLOWING THE FOOTING DIAGRAM BELOW, DIG THREE HOLES APPROXIMATELY 24" DEEP BY 12" ROUND, DISTANCE BETWEEN HOLES IS 25 1/4" APPROXIMATELY, CENTER TO CENTER.

STEP 2

SET THE BENCH END FRAMES IN HOLES ON THE SAME CENTER DISTANCE AS THE HOLES. MAKE SURE THE BENCH END FRAMES ARE 18" ABOVE GROUND LEVEL AND ARE IN LINE. PLUMB THE FRAMES AND FILL WITH CONCRETE.

LET STAND FOR 24 HOURS BEFORE COMPLETING THESE ASSEMBLY INSTRUCTIONS.

STEP 3

MOUNT THE COATED FORMED SEAT TO THE FRAME BY MEANS OF TWELVE 5/16" X 1 1/2" HEXBOLTS, TWENTY-FOUR 5/16" FLAT WASHERS, AND TWELVE NYLOCK NUTS THROUGH THE SLOTTED HOLES ON THE FRAME AND THROUGH THE SLOTTED HOLES ON THE SEATS.

STEP 4

DO NOT

TIGHTEN ALL NUTS ON ALL BOLTS AND PLACE THE BOLT GUARDS ON ALL NUTS.

OVER TIGHTEN THE NUTS AS THIS COULD CAUSE THE PLASTISOL COATING TO CRACK.

FOOTING DETAIL:

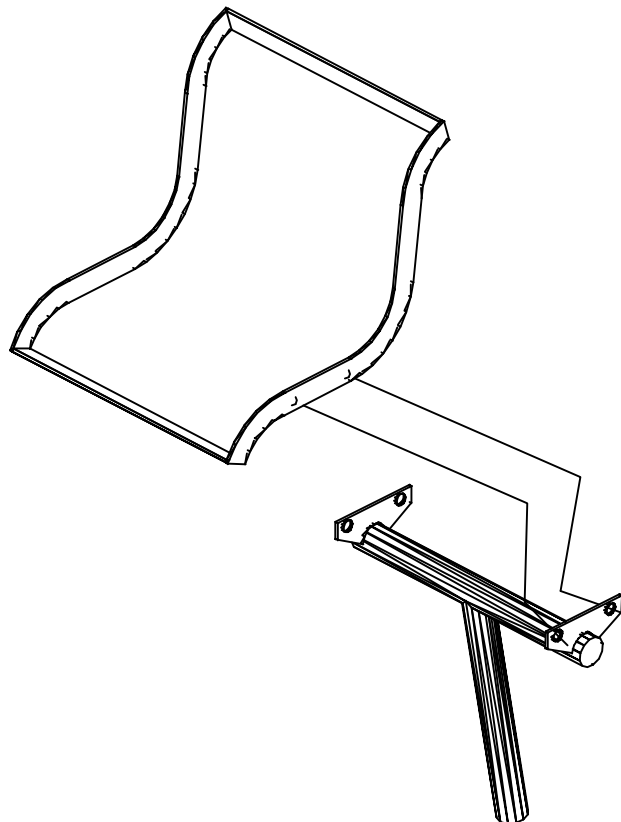
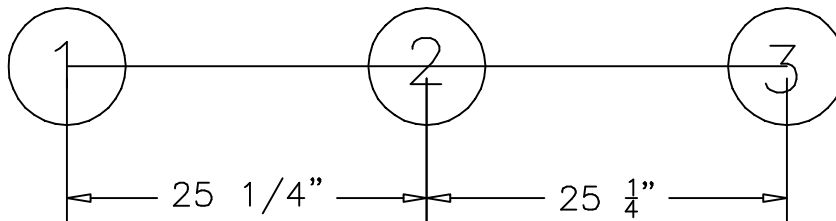

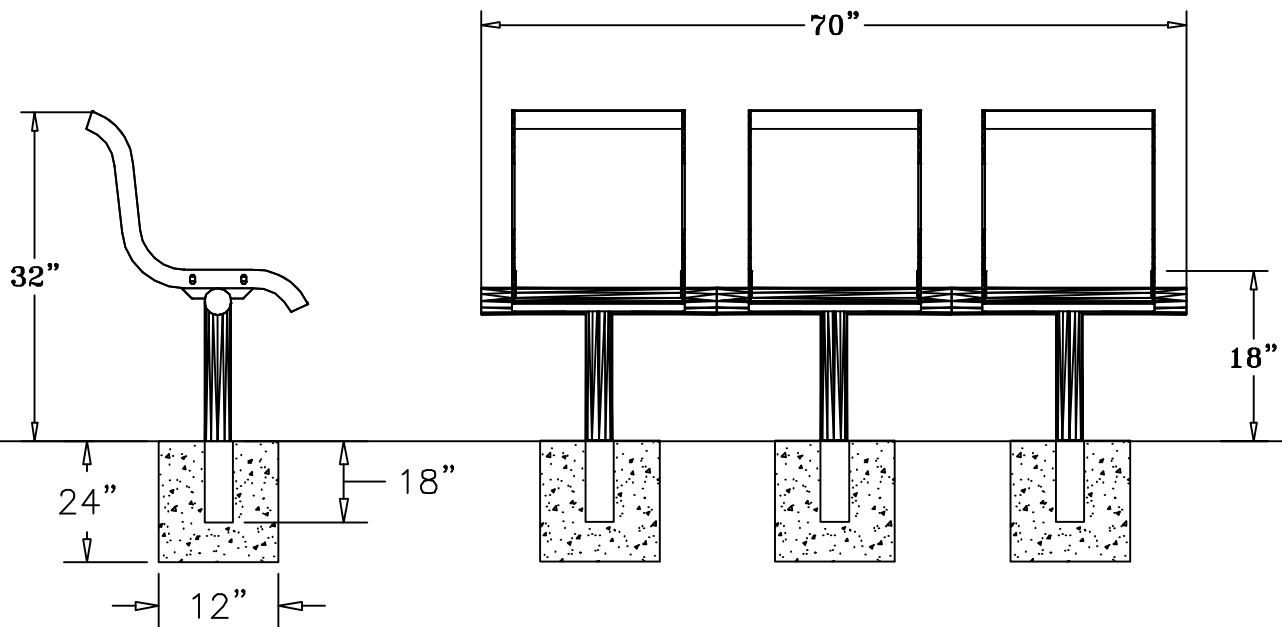

SPECIFICATIONS

70" x 32" POLY VINYL COATED DOWNTOWN STYLE CLASSIC 3 SEAT BENCH WITH BACK. THE FRAME IS INGROUND MOUNT DESIGN.

COATED WITH A 1/8" TO 1/4" THICK PLASTISOL ULTRAVIOLET STABILIZED VINYL COATING FUSED AND BAKED TO A 90% GLOSS

SEAT HEIGHT IS 18" APPROXIMATELY, BENCH HEIGHT IS 32" APPROXIMATELY. TOTAL OVERALL DIMENSIONS ARE 70" X 32".

SEATS ARE MADE FROM PRECISION CUT RIBBED STEEL.
ALL BRACES ARE MADE FROM 11 GA FLAT STEEL.

FRAME IS A 2 7/8" HEAVY DUTY GALVANIZED STEEL TUBING THAT IS GALVANIZED INSIDE AND OUT AND MEETS OR EXCEEDS THE YIELD AND TENSIAL OF SCH 40 PIPE. CONSTRUCTED SO AS TO PROHIBIT RAIN WATER FROM COLLECTING AT GROUND LEVEL. COATED WITH A BAKED ON POLYESTER POWDER COAT FINISH.

ALL HARDWARE IS NON-CORROSIVE.
WEIGHT FOR THE BWBCDTCLASS3S IS 152 LBS.

MAINTENANCE

To maintain luster it is recommended to wash, rinse, and dry the units after prolonged use. Check for loose bolts and nuts and tighten as needed. Contact the factory for genuine Webcoat part replacements if needed.