



# BWBDS3SM

**3 SEAT  
DOWNTOWN BENCH WITH BACK  
SURFACE MOUNT DESIGN**

WEBCOAT PRODUCTS  
P.O. BOX 3160  
McALESTER, OKLAHOMA 74501  
1-800-505-5101  
FAX: (918)426-5924  
E-MAIL: WEBCOAT@WEBCOAT.COM

Please take the time to locate and identify each part. Assemble the units on a smooth flat surface. It is also helpful to lay the tops and seats on cardboard or a drop cloth to prevent scratching of the surface during assembly. All parts have been pre-cut and pre-drilled for ease of assembly. All holes are slotted to allow for easy assembly and for final levelling of tops and seats to frames. Fully assemble all parts without totally tightening nuts and bolts. After all assembled go back and retighten nuts to bolts. DO NOT OVER TIGHTEN NUTS TO BOLTS. Over tightened nuts can crack the plastisol coating. All the necessary quantities of parts required are listed in this assembly instructions.

**DO NOT BEGIN ASSEMBLY UNTIL YOU HAVE READ THESE INSTRUCTIONS AND ARE FAMILIAR WITH THE PARTS.**



# PARTS IDENTIFICATION

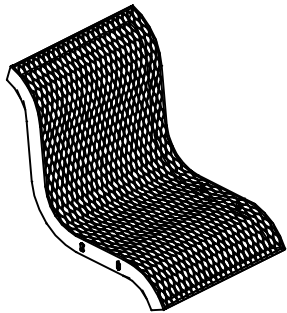

(A) SLINE DT SEAT

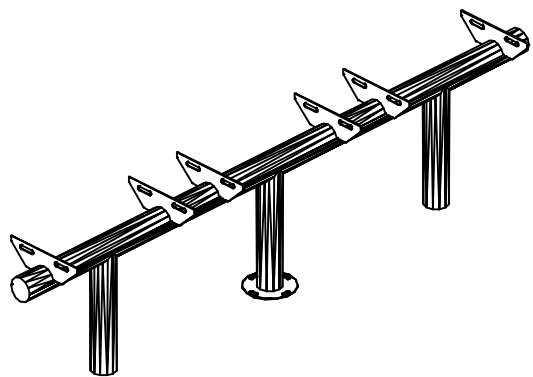

(B) SLINE FRAME

## PARTS LIST

ITEM	PART#	DESCRIPTION	QTY.
ITEM ASWBPTS		SLINE SEAT	3
ITEMB FDTSSM		SLINE FRAME-3	1

ITEM	HARDWARE DESCRIPTION	QTY.
HW1	5/16" X 18 NYL LOCKNUTS	12
HW2	5/16" X 18GA CAP BOLTS	12
HW3	5/16" FLAT WASHERS	36
HW4	BOLT GUARDS	12

ASSEMBLY TOOLS REQUIRED  
2- 1/2" WRENCHES

## HARDWARE IDENTIFICATION



(HW1) 5/16" X 18  
NYL LOCKNUTS



(HW2) 5/16" X 18  
GAUGE CAP BOLTS



(HW3) 5/16"  
FLAT WASHERS



(HW4) BOLT  
GUARDS

# ASSEMBLY PROCEDURES

## STEP 1

FOLLOWING THE DIAGRAM BELOW, MOUNT THE FRAME TO THE SURFACE.  
TOTAL DISTANCE BETWEEN FRAMES 1 AND 2 IS 27" CENTER TO CENTER.  
**SURFACE MOUNTING HARDWARE IS NOT INCLUDED.**

## STEP 2

MOUNT THE SEAT BY MEANS OF FOUR 5/16" X 1 1/2" HEXBOLTS, EIGHT 5/16" FLAT WASHERS, AND FOUR 5/16" NYLOCK NUTS THROUGH THE SLOTTED HOLES ON THE SEATS AND THROUGH THE SLOTTED HOLES ON THE ANGLE IRON OF THE FRAMES.

## STEP 3

TIGHTEN ALL NUTS ON ALL BOLTS AND PLACE THE BOLT GUARDS ON ALL NUTS.  
**OVER TIGHTEN THE NUTS AS THIS COULD CAUSE THE PLASTISOL COATING TO CRACK.**

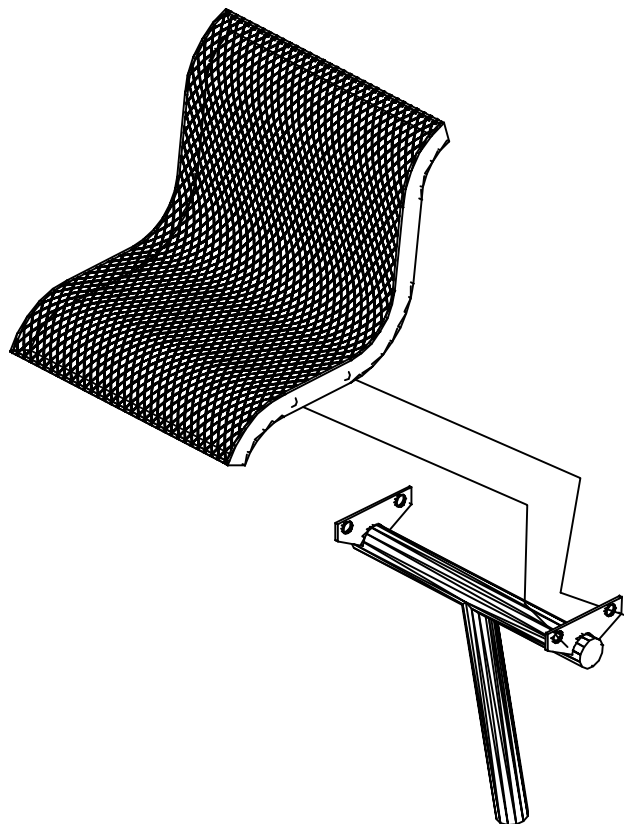

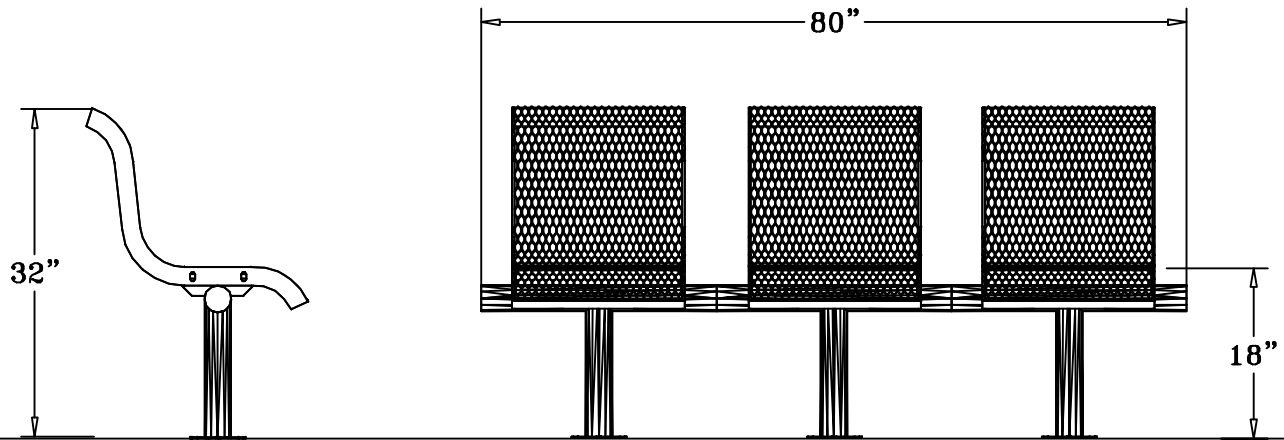

## SPECIFICATIONS

80" x 32" POLY VINYL COATED DOWNTOWN STYLE BENCH WITH BACK.  
THE FRAME IS SURFACE MOUNT DESIGN.

COATED WITH A 1/8" TO 1/4" THICK PLASTISOL ULTRAVIOLET STABILIZED VINYL COATING  
FUSED AND BAKED TO A 90% GLOSS

SEAT HEIGHT IS 18" APPROXIMATELY, BENCH HEIGHT IS 32" APPROXIMATELY.  
TOTAL OVERALL DIMENSIONS ARE 80" X 32".

SEATS ARE MADE FROM #9 EXPANDED METAL. ALL BRACES ARE MADE FROM 11 GA FLAT STEEL.

FRAME IS A 2 7/8" HEAVY DUTY GALVANIZED STEEL TUBING THAT IS GALVANIZED INSIDE  
AND OUT AND MEETS OR EXCEEDS THE YIELD AND TENSIAL OF SCH 40 PIPE. CONSTRUCTED SO AS  
TO PROHIBIT RAIN WATER FROM COLLECTING AT GROUND LEVEL. COATED WITH A BAKED ON  
POLYESTER POWDER COAT FINISH.

ALL HARDWARE IS NON-CORROSIVE.  
WEIGHT FOR THE BWBCDTS3SM IS 160 LBS.

## MAINTENANCE

To maintain luster it is recommended to wash, rinse, and dry the units after prolonged use.  
Check for loose bolts and nuts and tighten as needed. Contact the factory for genuine  
Webcoat part replacements if needed.