



T30MAGNAS

**30" MAGNA STYLE TABLE
INGROUND MOUNT DESIGN**

WEBCOAT PRODUCTS
P.O. BOX 3160
McALESTER, OKLAHOMA 74501
1-800-505-5101
FAX: (918)426-5924
E-MAIL: WEBCOAT@WEBCOAT.COM

Please take the time to locate and identify each part. Assemble the units on a smooth flat surface. It is also helpful to lay the tops and seats on cardboard or a drop cloth to prevent scratching of the surface during assembly. All parts have been pre-cut and pre-drilled for ease of assembly. All holes are slotted to allow for easy assembly and for final levelling of tops and seats to frames. Fully assemble all parts without totally tightening nuts and bolts. After all assembled go back and retighten nuts to bolts. **DO NOT OVER TIGHTEN NUTS TO BOLTS.** Over tightened nuts can crack the plastisol coating. All the necessary quantities of parts required are listed in this assembly instructions.

DO NOT BEGIN ASSEMBLY UNTIL YOU HAVE READ THESE INSTRUCTIONS AND ARE FAMILIAR WITH THE PARTS.

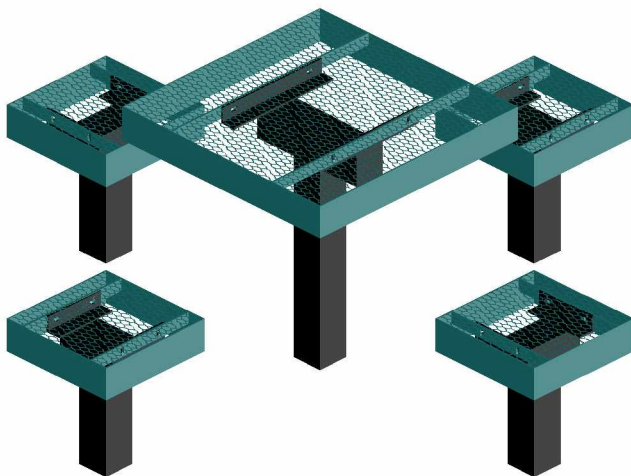

PARTS IDENTIFICATION

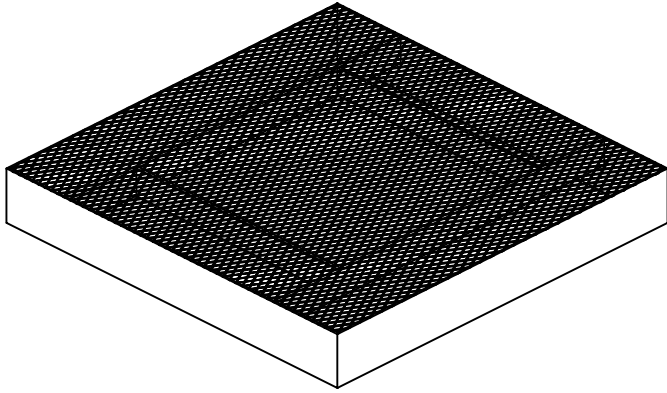

(A) 30" SQ. MAGNA TOP

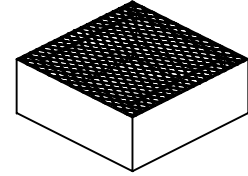

(B) 15" SQ. MAGNA SEAT

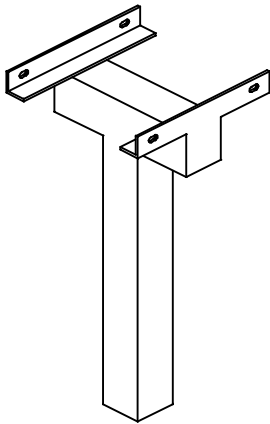

(C) CENTER POST

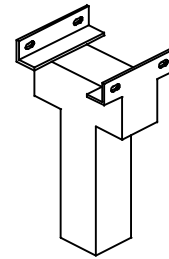

(D) SEAT POST

PARTS LIST

ITEM	PART#	DESCRIPTION	QTY.
A	TT30MAGNA	30" SQ. MAGNA TOP	1
B	S15MAGNA	15" SQ. MAGNA SEAT	4
C	F30MAGCPI	CENTER POST	1
D	F30MAGSPI	SEAT POST	4

ITEM	HARDWARE DESCRIPTION	QTY.
HW1	5/16" X 18 NYL LOCKNUTS	20
HW2	5/16" X 18GA CAP BOLTS	20
HW3	5/16" FLAT WASHERS	40
HW4	BOLT GUARDS	20

ASSEMBLY TOOLS REQUIRED
2- 1/2" WRENCHES

HARDWARE IDENTIFICATION



(HW1) 5/16" X 18
NYL LOCKNUTS



(HW2) 5/16" X 18
GAUGE CAP BOLTS



(HW3) 5/16"
FLAT WASHERS



(HW4) BOLT
GUARDS

ASSEMBLY PROCEDURES

STEP 1

USING THE FOOTING DIAGRAM BELOW; DIG FIVE 24" DEEP BY 12" ROUND HOLES, ONE CENTER HOLE AND THE OTHER TWO HOLES TO BE PLACED 27 1/2" FROM THE CENTER HOLE. SET POSTS 18" INTO HOLES, PROP IN A PLUMB AND LEVEL POSITION. POUR CONCRETE AND **LET STAND FOR 24 HOURS BEFORE COMPLETING THESE ASSEMBLY INSTRUCTIONS.**

STEP 2

MOUNT TOP ON CENTER PEDESTAL POST BY MATCHING UP THE HOLES ON THE BRACES OF THE TOP TO THE HOLES IN THE 2" X 2" ANGLE IRON ON THE CENTER POST. FASTEN BY MEANS OF FOUR 5/16" X 1 1/2" HEXBOLTS, EIGHT 5/16" FLAT WASHERS, AND FOUR 5/16" NYLOCK NUTS.

STEP 3

MOUNT SEATS ON SEAT PEDESTAL POST BY MATCHING UP THE HOLES ON THE BRACES OF THE SEAT TO THE HOLES IN THE 2" X 2" ANGLE IRON ON THE SEAT POST. FASTEN BY MEANS OF EIGHT 5/16" X 1 1/2" HEXBOLTS, SIXTEEN 5/16" FLAT WASHERS, AND EIGHT 5/16" NYLOCK NUTS.

STEP 4

TIGHTEN ALL NUTS ON ALL BOLTS AND PLACE THE BOLT GUARDS ON ALL NUTS. **DO NOT OVER TIGHTEN AS THIS WILL CAUSE THE PLASTISOL COATING TO CRACK.**

FOOTING DIAGRAM:

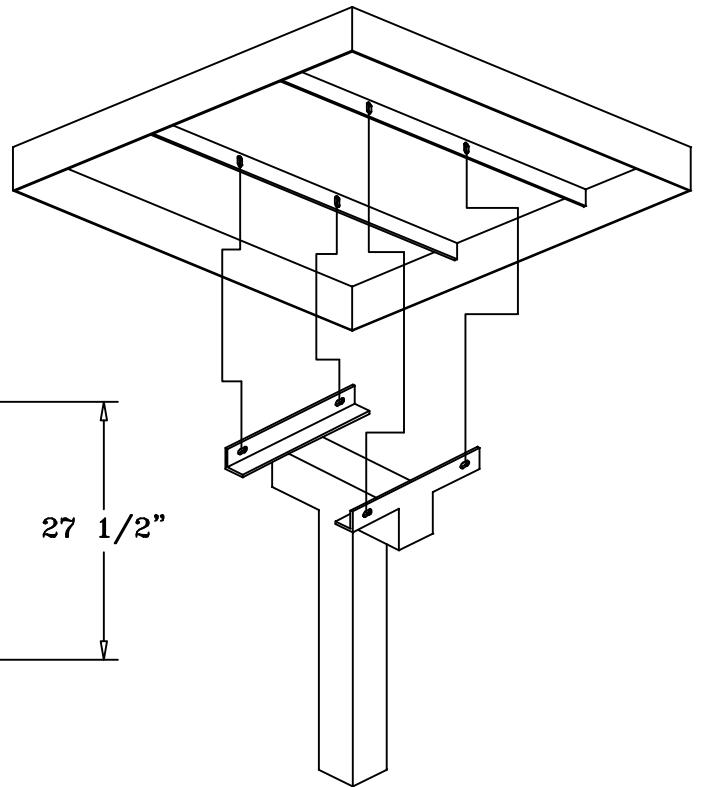
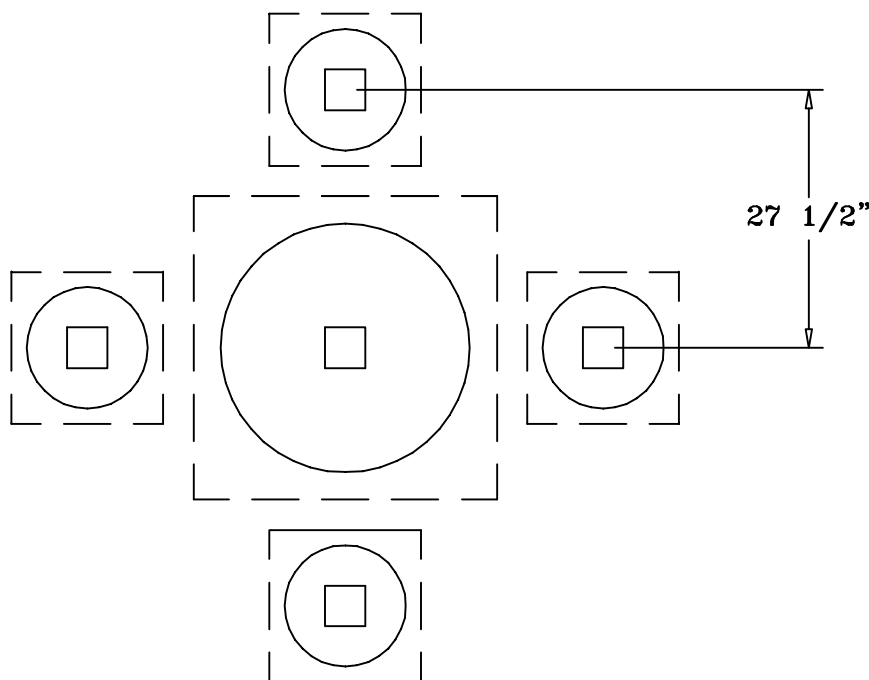

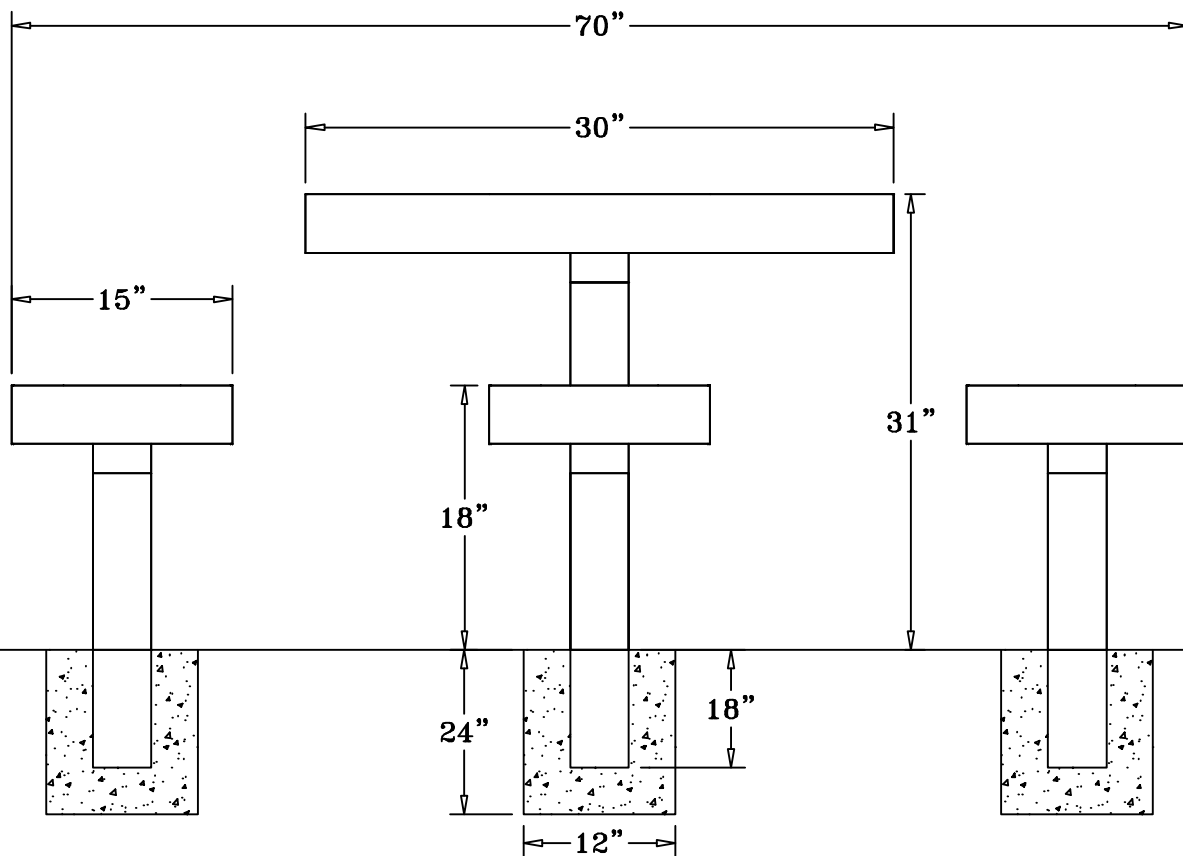

SPECIFICATIONS

30" SQ. POLY VINYL EXPANDED METAL TABLE TOP WITH FOUR UNATTACHED 15" SQ. SEATS. THE FRAME IS A 4" SQ. INGROUND MOUNT PEDESTAL DESIGN.

COATED WITH A 1/8" TO 1/4" THICK PLASTISOL ULTRAVIOLET STABILIZED VINYL COATING FUSED AND BAKED TO A 90% GLOSS.

TABLE HEIGHT IS 31" APPROXIMATELY. SEAT HEIGHT IS 18" APPROXIMATELY. TOTAL OVERALL SQUARED DIMENSION IS 70".

TOP AND SEATS ARE MADE WITH HEAVY DUTY 3/4" #9 EXPANDED METAL INSIDE A FRAME MADE FROM 4" WIDE FLAT STEEL. EXTRA CROSS BRACES ARE MADE FROM 1/4" THICK STEEL FLATS FOR ADDED STRENGTH.

FRAME FOR THE TOP AND SEATS ARE MADE FROM A 4" SQUARE POST MOUNTED BY ANGLE IRON TO THE CENTER OF THE TABLE TOP AND CENTER OF THE SEATS. COATED WITH A BAKED ON POLYESTER POWDER COAT FINISH.

ALL HARDWARE IS NON-CORROSIVE
WEIGHT FOR THE T30MAGNAS IS 240 LBS.

MAINTENANCE

To maintain luster it is recommended to wash, rinse, and dry the units after prolonged use. Check for loose bolts and nuts and tighten as needed. Contact the factory for genuine Webcoat part replacements if needed.