



T40MAGNAS

40" SQUARE MAGNA TABLE
INGROUND MOUNT DESIGN

WEBCOAT PRODUCTS
P.O. BOX 3160
McALESTER, OKLAHOMA 74501
1-800-505-5101
FAX: (918)426-5924
E-MAIL: WEBCOAT@WEBCOAT.COM

Please take the time to locate and identify each part. Assemble the units on a smooth flat surface. It is also helpful to lay the tops and seats on cardboard or a drop cloth to prevent scratching of the surface during assembly. All parts have been pre-cut and pre-drilled for ease of assembly. All holes are slotted to allow for easy assembly and for final levelling of tops and seats to frames. Fully assemble all parts without totally tightening nuts and bolts. After all assembled go back and retighten nuts to bolts. DO NOT OVER TIGHTEN NUTS TO BOLTS. Over tightened nuts can crack the plastisol coating. All the necessary quantities of parts required are listed in this assembly instructions.

DO NOT BEGIN ASSEMBLY UNTIL YOU HAVE READ THESE INSTRUCTIONS AND ARE FAMILIAR WITH THE PARTS.

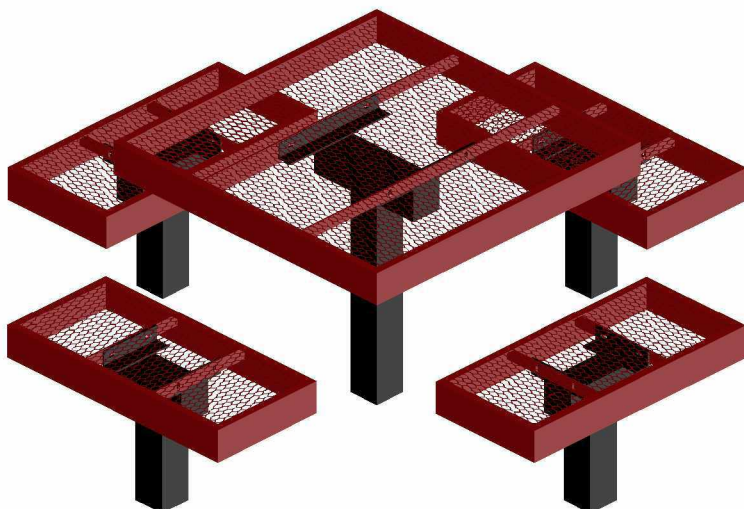

PARTS IDENTIFICATION

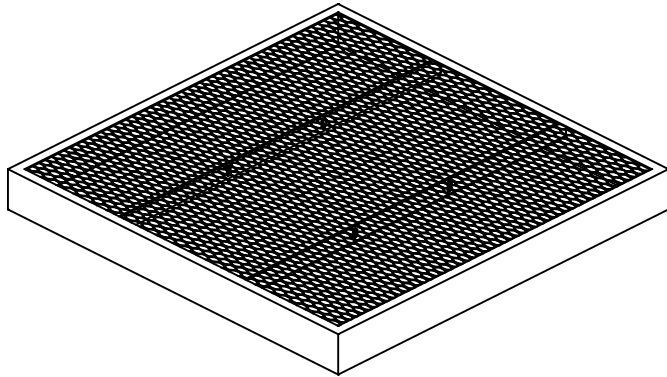

(A) 40" SQ. MAGNA TOP

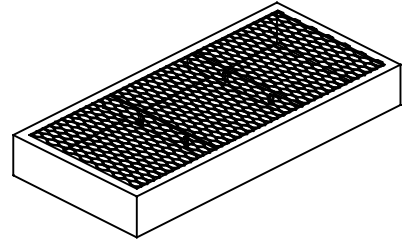

(B) 32" MAGNA SEAT

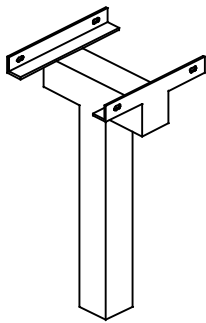

(C) 40" MAGNA CENTER POST

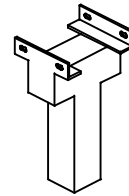

(D) 40" MAGNA SEAT POST

PARTS LIST

ITEM	PART#	DESCRIPTION	QTY.
A	TT40 MAGNA	40" SQ. MAGNA TOP	1
B	S32MAGNA	32" SQ. MAGNA SEAT	4
C	F40MAGCPI	4" SQ. CENTER POST	1
D	F40MAGSPI	4" SQ. SEAT POST	4

ITEM	HARDWARE DESCRIPTION	QTY.
HW1	5/16" X 18 NYL LOCKNUTS	20
HW2	5/16" X 18GA CAP BOLTS	20
HW3	5/16" FLAT WASHERS	40
HW4	BOLT GUARDS	20

ASSEMBLY TOOLS REQUIRED
2- 1/2" WRENCHES

HARDWARE IDENTIFICATION



(HW1) 5/16" X 18
NYL LOCKNUTS



(HW2) 5/16" X 18
GAUGE CAP BOLTS



(HW3) 5/16"
FLAT WASHERS



(HW4) BOLT
GUARDS

ASSEMBLY PROCEDURES

STEP 1

USING THE FOOTING DIAGRAM BELOW, DIG FIVE 24" DEEP BY 12" ROUND HOLES, ONE CENTER HOLE AND THE OTHER FOUR HOLES TO BE PLACED 32 1/2" FROM THE CENTER HOLE. SET POSTS 18" INTO HOLES, PROP IN A PLUMB AND LEVEL POSITION. POUR CONCRETE AND **LET STAND FOR 24 HOURS BEFORE COMPLETING THESE ASSEMBLY INSTRUCTIONS.**

STEP 2

MOUNT TOP ON CENTER PEDESTAL POST BY MATCHING UP THE HOLES ON THE BRACES OF THE TOP TO THE HOLES IN THE 2" X 2" ANGLE IRON ON THE CENTER POST. FASTEN BY MEANS OF FOUR 5/16" X 1 1/2" HEXBOLTS, EIGHT 5/16" FLAT WASHERS, AND FOUR 5/16" NYLOCK NUTS.

STEP 3

MOUNT SEATS ON SEAT PEDESTAL POST BY MATCHING UP THE HOLES ON THE BRACES OF THE SEAT TO THE HOLES IN THE 2" X 2" ANGLE IRON ON THE SEAT POST. FASTEN BY MEANS OF EIGHT 5/16" X 1 1/2" HEXBOLTS, SIXTEEN 5/16" FLAT WASHERS, AND EIGHT 5/16" NYLOCK NUTS. REPEAT FOR EACH SEAT.

STEP 4

TIGHTEN ALL NUTS ON ALL BOLTS AND PLACE THE BOLT GUARDS ON ALL NUTS.
DO NOT OVER TIGHTEN AS THIS WILL CAUSE THE PLASTISOL COATING TO CRACK.

FOOTING DIAGRAM:

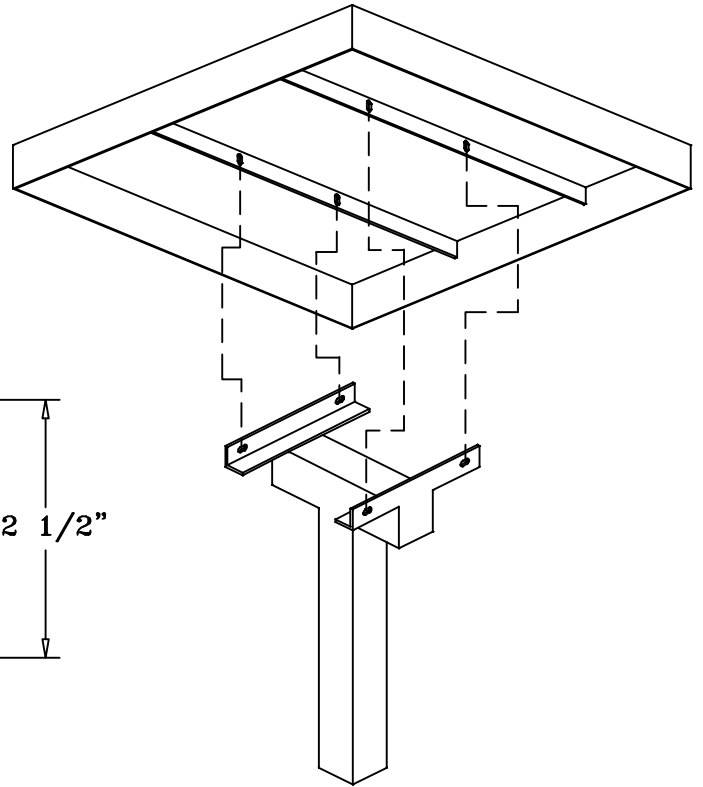
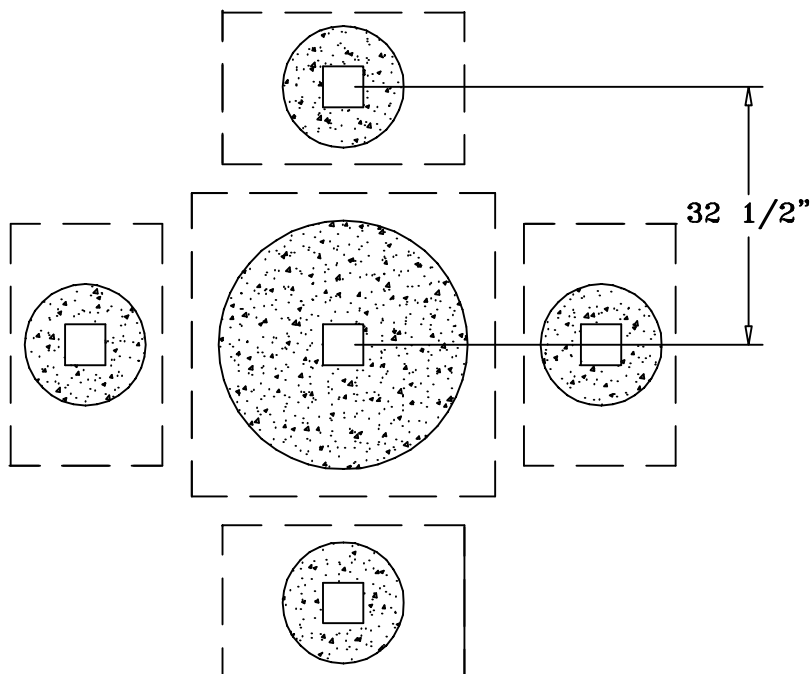

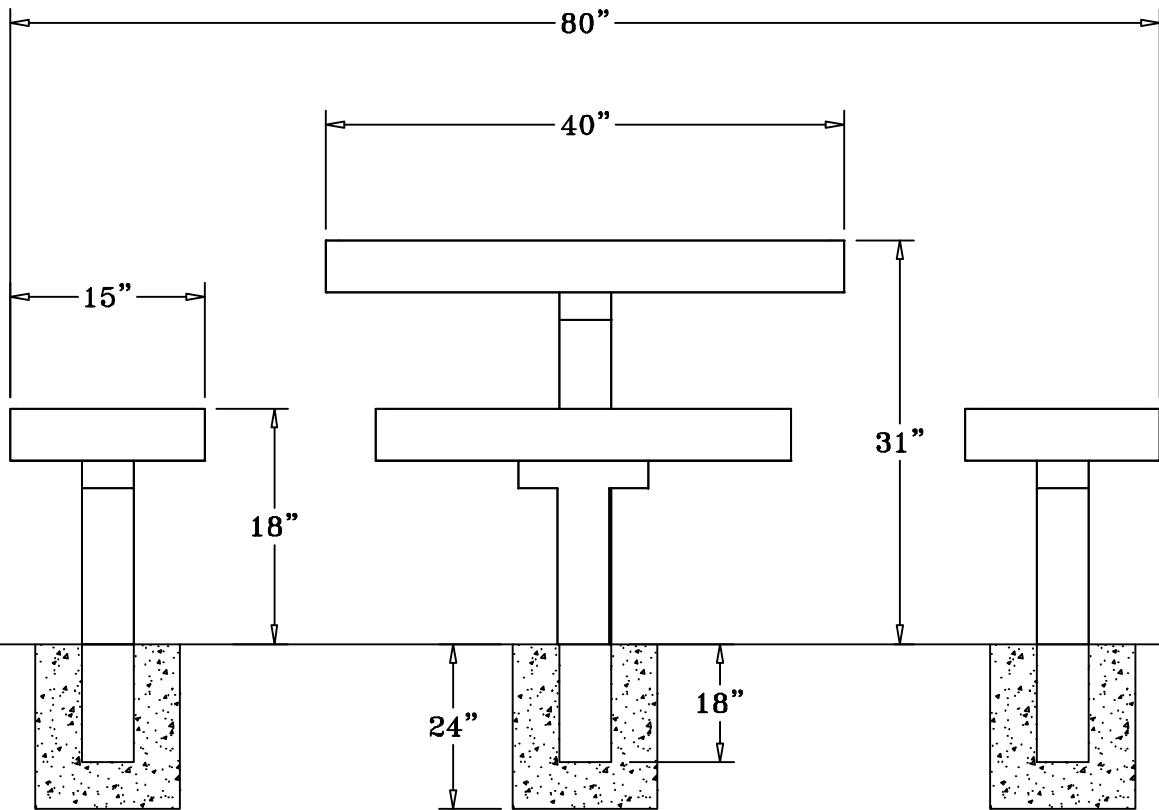

SPECIFICATIONS

40" SQ. POLY VINYL EXPANDED METAL TABLE TOP WITH FOUR ATTACHED 32" X 15" SEATS. THE FRAME IS A 4" SQ. INGROUND MOUNT PEDESTAL DESIGN.

COATED WITH A 1/8" TO 1/4" THICK PLASTISOL ULTRAVIOLET STABILIZED VINYL COATING FUSED AND BAKED TO A 90% GLOSS.

TABLE HEIGHT IS 31" APPROXIMATELY. SEAT HEIGHT IS 18" APPROXIMATELY. TOTAL OVERALL SQUARED DIMENSION IS 80".

TOP AND SEATS ARE MADE WITH HEAVY DUTY 3/4" #9 EXPANDED METAL INSIDE A 1" X 4" X 1/8" FORMED ANGLE FRAME. ALL CENTER BRACES ARE MADE FROM 1/4" THICK FLAT STEEL THAT ADDS EXTRA STRENGTH TO THE TOPS AND SEATS.

FRAME FOR THE TOP AND SEATS ARE MADE FROM A 4" SQUARE POST MOUNTED BY ANGLE IRON TO THE CENTER OF THE TABLE TOP AND CENTER OF THE SEATS. COATED WITH A BAKED ON POLYESTER POWDER COAT FINISH.

ALL HARDWARE IS NON-CORROSIVE
WEIGHT FOR THE T40MAGNAS IS 295 LBS.

MAINTENANCE

To maintain luster it is recommended to wash, rinse, and dry the units after prolonged use. Check for loose bolts and nuts and tighten as needed. Contact the factory for genuine Webcoat part replacements if needed.