



T46ULPERF-3ADA

46" SQ. UNLIMITED PERFORATED STYLE
3 SEAT HANDICAP TABLE
PORTABLE DESIGN

WEBCOAT PRODUCTS
P.O. BOX 3160
McALESTER, OKLAHOMA 74501
1-800-505-5101
FAX: (918)426-5924
E-MAIL: WEBCOAT@WEBCOAT.COM

Please take the time to locate and identify each part. Assemble the units on a smooth flat surface. It is also helpful to lay the tops and seats on cardboard or a drop cloth to prevent scratching of the surface during assembly. All parts have been pre-cut and pre-drilled for ease of assembly. All holes are slotted to allow for easy assembly and for final levelling of tops and seats to frames. Fully assemble all parts without totally tightening nuts and bolts. After all assembled go back and retighten nuts to bolts. DO NOT OVER TIGHTEN NUTS TO BOLTS. Over tightened nuts can crack the plastisol coating. All the necessary quantities of parts required are listed in this assembly instructions.

DO NOT BEGIN ASSEMBLY UNTIL YOU HAVE READ THESE INSTRUCTIONS AND ARE FAMILIAR WITH THE PARTS.



PARTS IDENTIFICATION

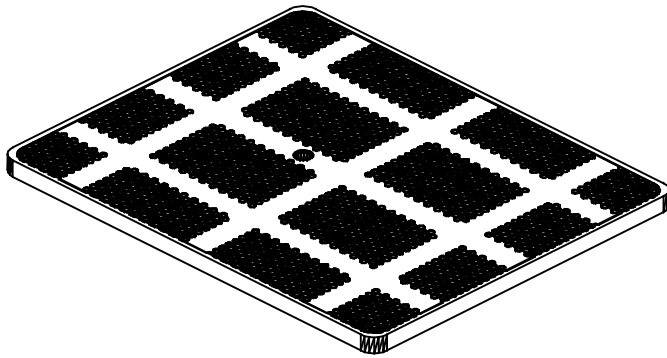

(A) 46" ULPERF-3ADA TOP

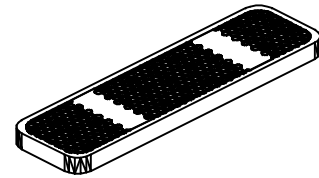

(B) 38" ULPERF SEAT

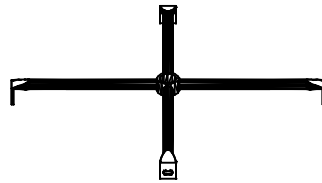

(C) CROSS BRACE

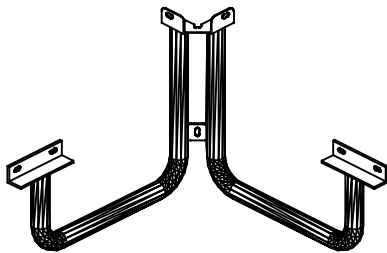

(D) CORNER LEGS

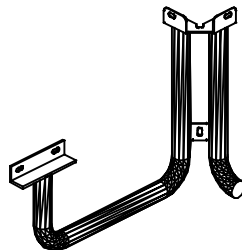

(E) CORNER LEGS-L

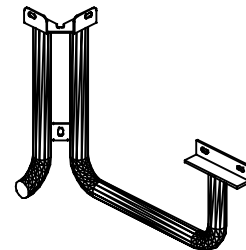

(F) CORNER LEGS-R

PARTS LIST

ITEM	PART#	DESCRIPTION	QTY.
A	TT46ULPERF-3ADA	46" SQ. ULPERF TOP	1
B	S38ULPERF	38" ULPERF SEAT	3
C	CB	CROSS BRACE	1
D	FSQ	CORNER LEGS	2
E	FSQ-L	CORNER LEGS-L	1
F	FSQ-R	CORNRE LEGS-R	1

ITEM	HARDWARE DESCRIPTION	QTY.
HW1	5/16" X 18 NYL LOCKNUTS	24
HW2	5/16" X 18GA CAP BOLTS	24
HW3	5/16" FLAT WASHERS	48
HW4	BOLT GUARDS	24

ASSEMBLY TOOLS REQUIRED
2- 1/2" WRENCHES

HARDWARE IDENTIFICATION



(HW1) 5/16" X 18
NYL LOCKNUTS

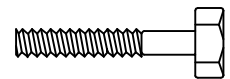

(HW2) 5/16" X 18
GAUGE CAP BOLTS



(HW3) 5/16"
FLAT WASHERS



(HW4) BOLT
GUARDS

ASSEMBLY PROCEDURES

STEP 1

LAY TOP UPSIDE DOWN ON A SMOOTH FLAT SURFACE. MOUNT ONE SET OF FRAMES TO EACH CORNER OF TABLE, SQUARED TO THE TOP. TABS WELDED ON FRAMES FOR CROSS BRACE MUST BE FACING EACH OTHER. ANGLE IRON ON FRAMES MUST BE BOLTED TO OUTSIDE OF BRACES ON TABLE TOP. FASTEN USING FOUR 5/16" X 1 1/2" CAP BOLTS, EIGHT 5/16" FLAT WASHERS AND FOUR 5/16" NYLOCK NUTS. HAND TIGHTEN ONLY AT THIS TIME.

STEP 2

PLACE THE CROSS BRACE ON THE INSIDE OF THE BOTTOM OF SQUARE MADE BY THE FOUR CORNER LEGS, MATCHING HOLES ON THE ENDS TO THE HOLES IN THE TAB WELDED BETWEEN THE LEGS OF EACH CORNER. ATTACH WITH FOUR 5/16" X 1 1/2" CAP BOLTS, EIGHT FLAT WASHERS AND FOUR 5/16" NYLOCK NUTS. HAND TIGHTEN ONLY AT THIS TIME.

STEP 3

CAREFULLY SET TABLE UPRIGHT. ATTACH THE SEATS TO FRAMES BY MEANS OF TWELVE 5/16" X 1 1/2" HEXBOLTS, TWENTY FOUR FLAT WASHERS AND TWELVE 5/16" NYLOCK NUTS. HAND TIGHTEN ONLY AT THIS TIME.

STEP 4

TIGHTEN ALL BOLTS IN ALTERNATING PATTERNS TO KEEP THE FRAMES STRAIGHT UNDER THE TOPS AND SEATS AS YOU ARE TIGHTENING.

1	CAP BOLT & WASHER
2	WASHER & LOCK NUT

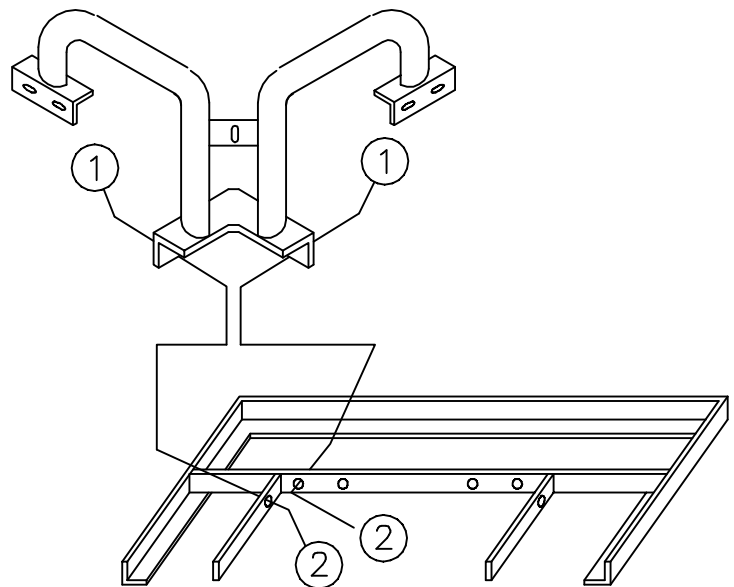
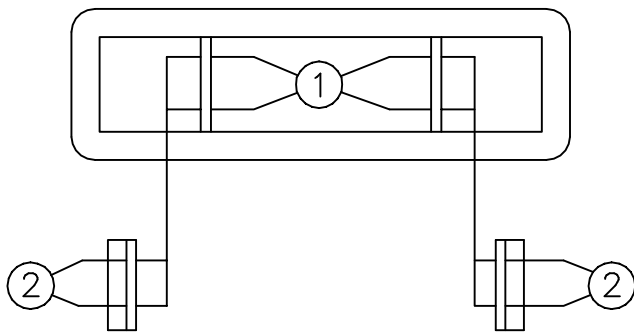

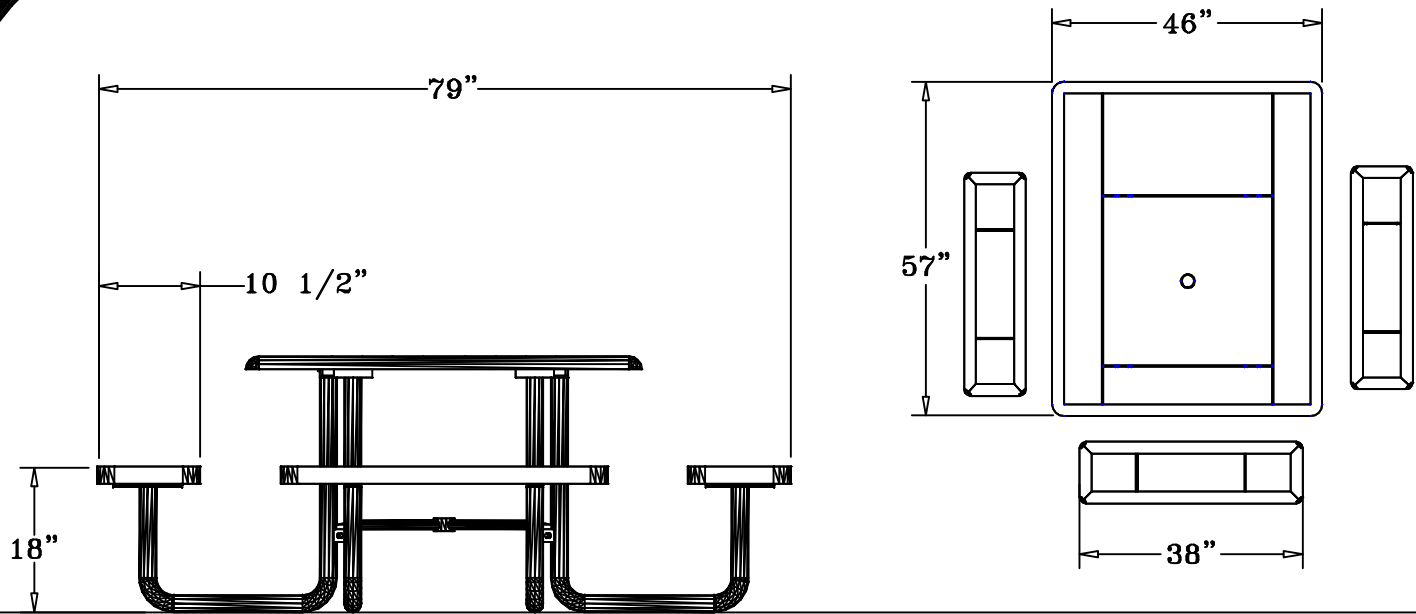

SPECIFICATIONS

46" X 57" PRECISION PUNCHED STEEL TABLE WITH THREE ATTACHED 38" X 10 1/2" SEATS. ALL CORNERS ARE ROUNDED. FRAME IS PORTABLE DESIGN.

COATED WITH A 1/8" TO 1/4" THICK PLASTISOL ULTRAVIOLET STABILIZED VINYL COATING FUSED AND BAKED TO A 90% GLOSS.

TABLE HEIGHT IS 31" APPROXIMATELY. SEAT HEIGHT IS 18" APPROXIMATELY. TOTAL OVERALL DIMENSION IS 79" X 73 1/2".

TOP AND SEATS ARE MADE OF 11 GAGE PUNCHED STEEL WITH 3/4" ϕ HOLES INSIDE OF A 2" X 3/4" X 1/8" ANGLE IRON FRAME. ALL CENTER BRACES ARE MADE FROM 1/4" X 1 1/2" FLAT STEEL.

FRAME IS A 2 7/8" HEAVY GALVANIZED STEEL TUBING THAT IS GALVANIZED INSIDE AND OUT AND MEETS OR EXCEEDS THE YIELD AND TENSILE OF SCH 40 PIPE. CONSTRUCTED SO AS TO PROHIBIT RAIN WATER FROM COLLECTING AT GROUND LEVEL. COATED WITH A BAKED ON POLYESTER POWDER COAT FINISH.

ALL HARDWARE IS NON-CORROSIVE.
WEIGHT FOR THE T46ULPERF-3ADA IS 285 LBS.

MAINTENANCE

To maintain luster it is recommended to wash, rinse, and dry the units after prolonged use. Check for loose bolts and nuts and tighten as needed. Contact the factory for genuine Webcoat part replacements if needed.