



T46WEB-3S

**46" SQUARE REGAL STYLE
3 SEAT PEDESTAL TABLE
INGROUND MOUNT DESIGN**

WEBCOAT PRODUCTS
P.O. BOX 3160
McALESTER, OKLAHOMA 74501
1-800-505-5101
FAX: (918)426-5924
E-MAIL: WEBCOAT@WEBCOAT.COM

Please take the time to locate and identify each part. Assemble the units on a smooth flat surface. It is also helpful to lay the tops and seats on cardboard or a drop cloth to prevent scratching of the surface during assembly. All parts have been pre-cut and pre-drilled for ease of assembly. All holes are slotted to allow for easy assembly and for final levelling of tops and seats to frames. Fully assemble all parts without totally tightening nuts and bolts. After all assembled go back and retighten nuts to bolts. **DO NOT OVER TIGHTEN NUTS TO BOLTS.** Over tightened nuts can crack the plastisol coating. All the necessary quantities of parts required are listed in this assembly instructions.

DO NOT BEGIN ASSEMBLY UNTIL YOU HAVE READ THESE INSTRUCTIONS AND ARE FAMILIAR WITH THE PARTS.



PARTS IDENTIFICATION

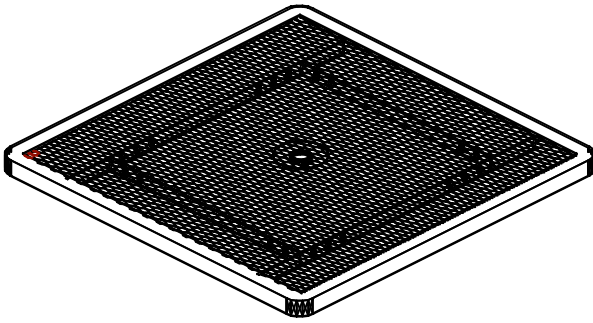

(A) 46" RC HDCP TOP

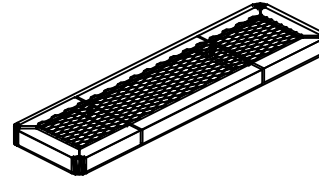

(B) 38" RC SEAT

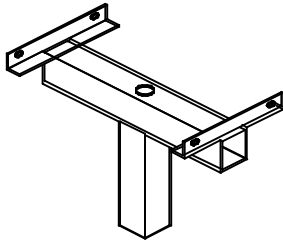

(C) CENTER POST

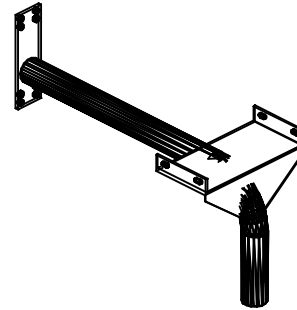

(D) PEDESTAL ARMS

PARTS LIST

ITEM	PART#	DESCRIPTION	QTY.
A	TT46RCHDCP	46" SQ. RC HDCP TOP	1
B	S38RC	38" RC SEAT	3
C	F46PEDCP	CENTER POST	1
D	F46WEBARM	PEDESTAL ARM	3

ITEM	HARDWARE DESCRIPTION	QTY.
HW1	5/16" X 18 NYL LOCKNUTS	16
HW2	5/16" X 18GA CAP BOLTS	16
HW3	5/16" FLAT WASHERS	32
HW4	BOLT GUARDS	16
HW5	5/8" BOLTS	6
HW6	5/8" NUTS	6

ASSEMBLY TOOLS REQUIRED
2- 1/2" WRENCHES

HARDWARE IDENTIFICATION



(HW1) 5/16" X 18
NYL LOCKNUTS



(HW2) 5/16" X 18
GAUGE CAP BOLTS



(HW5) 5/8" NUTS



(HW3) 5/16"
FLAT WASHERS



(HW4) BOLT
GUARDS



(HW6) 5/8" BOLTS

ASSEMBLY PROCEDURES

STEP 1

BOLT THE FOUR ARMS TO THE CENTER POST USING EIGHT 5/8" BOLTS AND EIGHT 5/8" NUTS,
Hand tighten at this time.

STEP 2

SET THE TOP ON THE CENTER POST ALIGNING HOLES IN TOP BRACES WITH HOLES IN THE ANGLE
IRON ON CENTER POST. FASTEN WITH FOUR 5/16" BOLTS, EIGHT WASHERS AND FOUR 5/16" NUTS.
Hand tighten at this time.

STEP 3

SET SEATS ON THE SEAT BRACKETS OF THE ARMS. BRACES ON SEAT SHOULD
SET TO THE OUTSIDE OF THE SEAT BRACKET ON THE ARM.
FASTEN WITH FOUR 5/16" BOLTS, EIGHT WASHERS AND FOUR 5/16" NUTS PER SEAT.

STEP 4

FOLLOWING THE POST PLACEMENT DIAGRAM BELOW: DIG FOUR HOLES APPROXIMATELY
24" DEEP X 12" ROUND SET POSTS IN HOLES; MAKING SURE THAT THE
OUTSIDE POSTS' ANGLE IRONS ARE FACING EACH OTHER.
DROP IN A PLUMB AND LEVEL POSITION.

STEP 5

POUR ALL CONCRETE AND LET STAND FOR 24 HOURS BEFORE COMPLETING THESE
ASSEMBLY INSTRUCTIONS.

STEP 6

TIGHTEN ALL BOLTS LEVELING AND SLIGNING PARTS AS YOU GO.
DO NOT OVER TIGHTEN AS THIS WILL CAUSE THE PLASTISOL COATING TO CRACK.

1	CAP BOLT & WASHER
2	WASHER & LOCK NUT

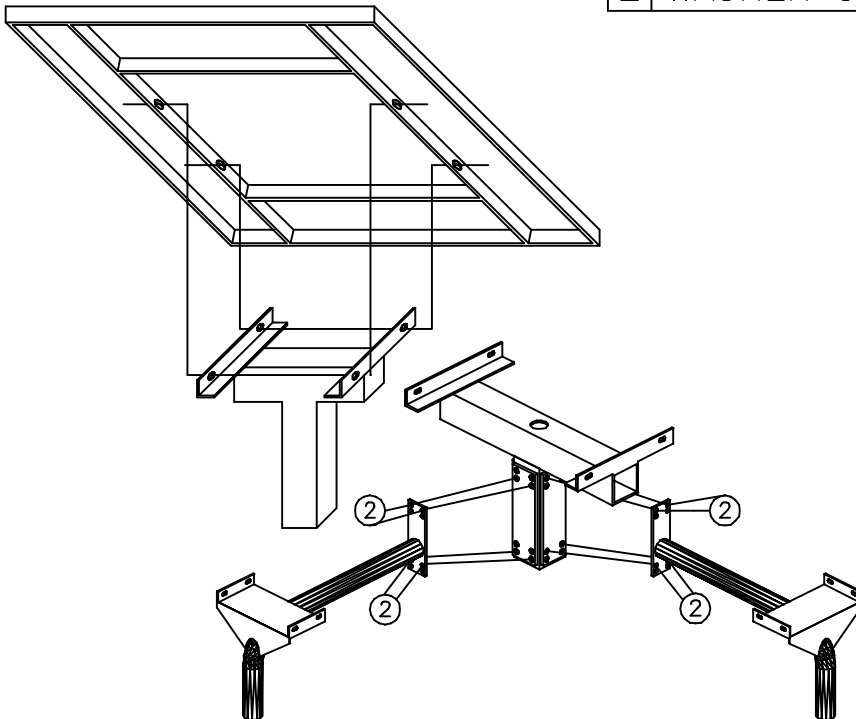

FOOTING DIAGRAM

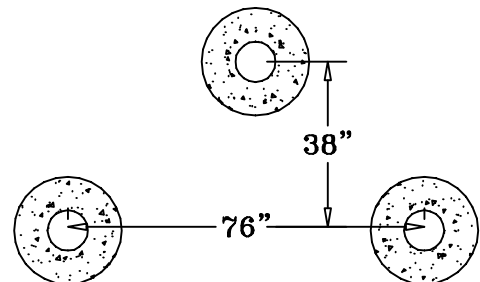

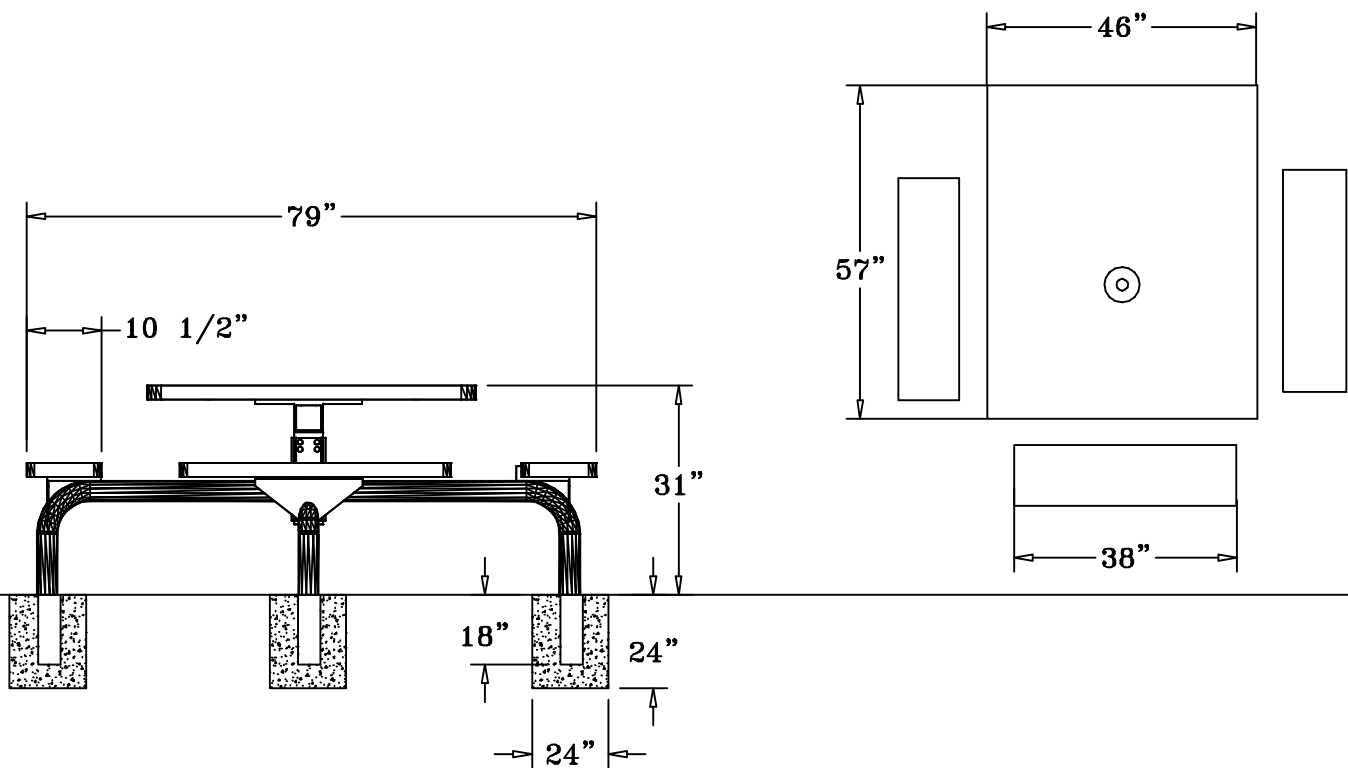

SPECIFICATIONS

46" x 57" ROUND CORNER TABLE WITH THREE ATTACHED 38" X 10 1/2" SEATS.
FRAME IS INGROUND MOUNT DESIGN.

COATED WITH A 1/8" TO 1/4" THICK PLASTISOL ULTRAVIOLET STABILIZED VINYL COATING FUSED
AND BAKED TO A 90% GLOSS.

TABLE HEIGHT IS 31" APPROXIMATELY. SEAT HEIGHT IS 18" APPROXIMATELY.
TOTAL OVERALL DIMENSION IS 79" x 68" APPROXIMATELY.

TOP AND SEATS ARE MADE WITH HEAVY DUTY 3/4" #9 EXPANDED METAL INSIDE OF A 2" X 2"
X 1/8" ANGLE IRON FRAME.

FRAME IS A SINGLE 4" X 4" PEDESTAL MOUNTED TO THE CENTER OF THE TABLE TOP. EXTENDING
OUT FROM THE 4" SQUARE TUBING ARE FOUR 2 7/8" ROUND TUBING ARMS THAT THE SEATS ARE
MOUNTED TO. COATED WITH A BAKED ON POLYESTER POWDER COAT FINISH.

ALL HARDWARE IS NON-CORROSIVE.

WEIGHT FOR THE T46WEB-3S IS 254 LBS.

MAINTENANCE

To maintain luster it is recommended to wash, rinse, and dry the units after prolonged use.
Check for loose bolts and nuts and tighten as needed. Contact the factory for genuine
Webcoat part replacements if needed.