



T46WEBINFS

46" SQUARE INFINITY STYLE
WEB TABLE
INGROUND MOUNT DESIGN

WEBCOAT PRODUCTS
P.O. BOX 3160
McALESTER, OKLAHOMA 74501
1-800-505-5101
FAX: (918)426-5924
E-MAIL: WEBCOAT@WEBCOAT.COM

Please take the time to locate and identify each part. Assemble the units on a smooth flat surface. It is also helpful to lay the tops and seats on cardboard or a drop cloth to prevent scratching of the surface during assembly. All parts have been pre-cut and pre-drilled for ease of assembly. All holes are slotted to allow for easy assembly and for final levelling of tops and seats to frames. Fully assemble all parts without totally tightening nuts and bolts. After all assembled go back and retighten nuts to bolts. DO NOT OVER TIGHTEN NUTS TO BOLTS. Over tightened nuts can crack the plastisol coating. All the necessary quantities of parts required are listed in this assembly instructions.

DO NOT BEGIN ASSEMBLY UNTIL YOU HAVE READ THESE INSTRUCTIONS AND ARE FAMILIAR WITH THE PARTS.

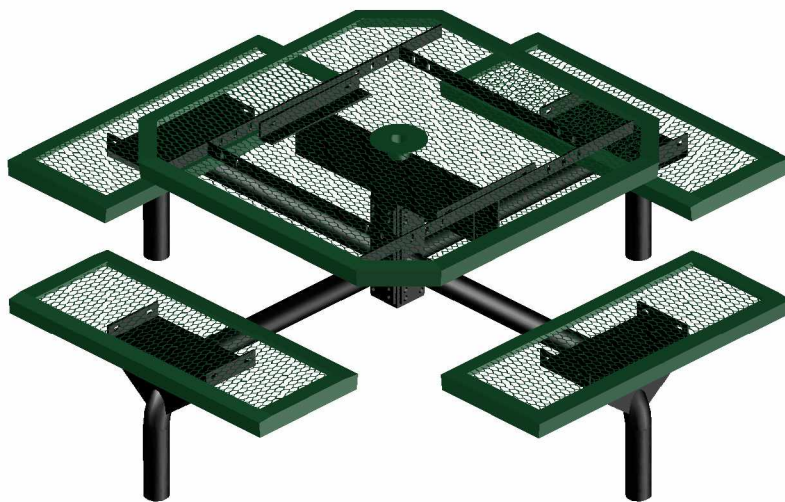

PARTS IDENTIFICATION

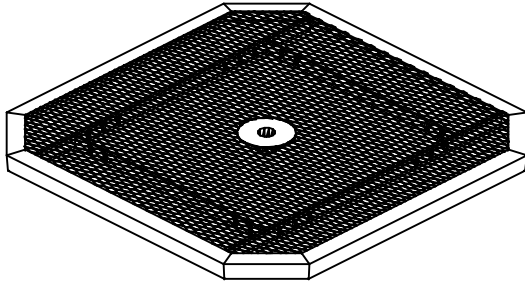

(A) 46" INF TOP

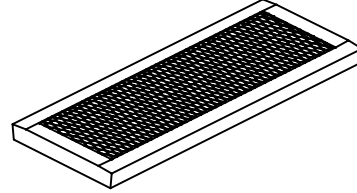

(B) 38" INF SEAT

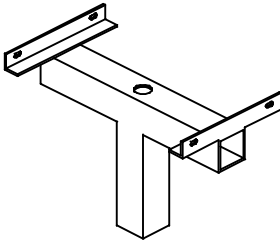

(C) CENTER POST

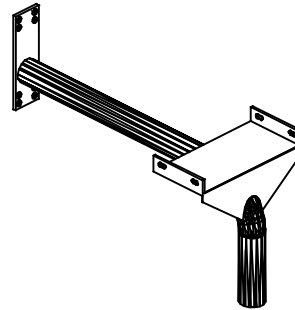

(D) PEDESTAL ARMS

PARTS LIST

ITEM	PART#	DESCRIPTION	QTY.
A	TT46INF	46" SQ. INF TOP	1
B	S38INF	38" INF SEAT	4
C	F46PEDCP	CENTER POST	1
D	F46WEBARM	PEDESTAL ARM	4

ITEM	HARDWARE DESCRIPTION	QTY.
HW1	5/16" X 18 NYL LOCKNUTS	20
HW2	5/16" X 18GA CAP BOLTS	20
HW3	5/16" FLAT WASHERS	40
HW4	BOLT GUARDS	20
HW5	5/8" BOLTS	8
HW6	5/8" NUTS	8

ASSEMBLY TOOLS REQUIRED
2- 1/2" WRENCHES

HARDWARE IDENTIFICATION



(HW1) 5/16" X 18
NYL LOCKNUTS



(HW2) 5/16" X 18
GAUGE CAP BOLTS



(HW5) 5/8" NUTS



(HW3) 5/16"
FLAT WASHERS



(HW4) BOLT
GUARDS



(HW6) 5/8" BOLTS

ASSEMBLY PROCEDURES

STEP 1

SET TABLE TOP ON TOP OF THE TABLE POSTS MATCHING THE HOLES IN THE CROSS BRACES OF TOP WITH HOLES IN THE ANGLE IRON BRACES OF THE TABLE POSTS. MOUNT BY MEANS OF FOUR 5/16" X 1 1/2" CAP BOLTS, EIGHT 5/16" FLAT WASHERS, AND FOUR 5/16" NYLOCK NUTS.

STEP 2

SET SEATS ON TOP OF THE SEAT POSTS MATCHING THE HOLES IN THE CROSS BRACES OF SEAT WITH HOLES IN THE ANGLE IRON BRACES OF THE SEAT POSTS. MOUNT BY MEANS OF SIXTEEN 5/16" X 1 1/2" CAP BOLTS, THIRTY TWO 5/16" FLAT WASHERS, AND SIXTEEN 5/16" NYLOCK NUTS.

STEP 3

FOLLOWING THE POST PLACEMENT DIAGRAM BELOW: DIG FOUR HOLES APPROXIMATELY 24" DEEP X 12" ROUND AND A DISTANCE OF 73" FROM CENTER TO CENTER. SET POSTS IN HOLES; MAKING SURE THAT THE OUTSIDE POSTS' ANGLE IRONS ARE FACING EACH OTHER. DROP IN A PLUMB AND LEVEL POSITION.

STEP 4

POUR ALL CONCRETE AND LET STAND FOR 24 HOURS BEFORE COMPLETING THESE ASSEMBLY INSTRUCTIONS.

STEP 5

TIGHTEN ALL NUTS ON BOLTS AND PLACE BOLT GUARDS ON ALL NUTS. DO NOT OVER TIGHTEN AS THIS COULD CAUSE THE PLASTISOL COATING TO CRACK.

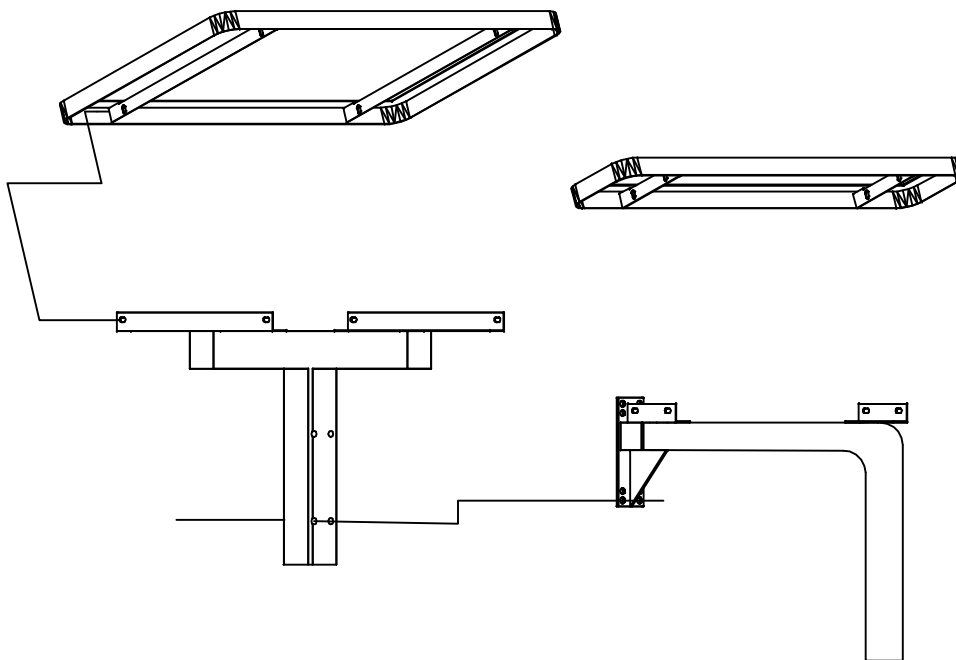

FOOTING DIAGRAM

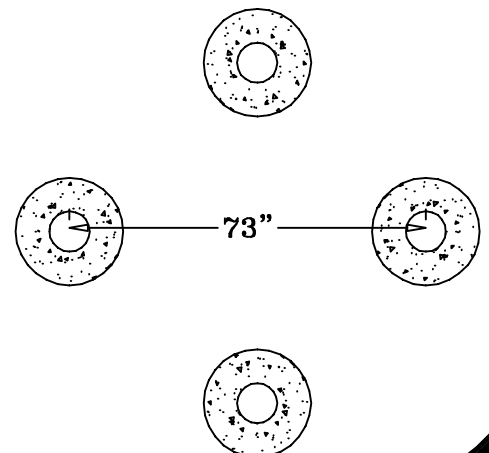

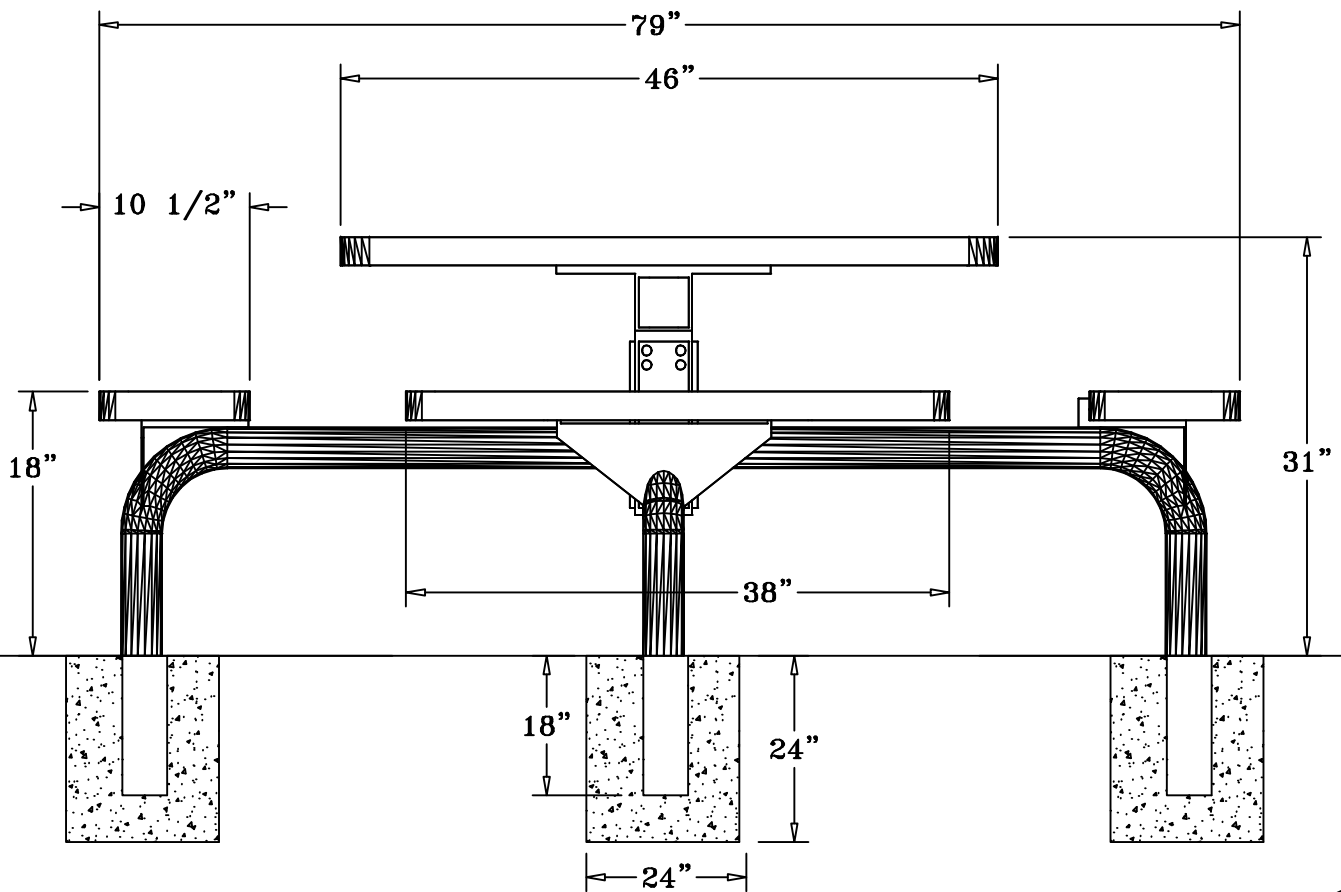

SPECIFICATIONS

46" SQ. POLY VINYL COATED EXPANDED METAL TABLE WITH FOUR ATTACHED 38" X 10 1/2" SEATS. TOP AND SEATS HAVE ANGLED SLOPING EDGES. FRAME IS INGROUND MOUNT DESIGN.

COATED WITH A 1/8" TO 1/4" THICK PLASTISOL ULTRAVIOLET STABILIZED VINYL COATING FUSED AND BAKED TO A 90% GLOSS.

TABLE HEIGHT IS 31" APPROXIMATELY. SEAT HEIGHT IS 18" APPROXIMATELY. TOTAL OVERALL SQUARED DIMENSION IS 79".

TOP AND SEATS ARE MADE WITH HEAVY DUTY 3/4" #9 EXPANDED METAL INSIDE OF A 2" X 2" X 1/8" ANGLE IRON FRAME.

FRAME IS A SINGLE 4" X 4" PEDESTAL MOUNTED TO THE CENTER OF THE TABLE TOP. EXTENDING OUT FROM THE 4" SQUARE TUBING ARE FOUR 2 7/8" ROUND TUBING ARMS THAT THE SEATS ARE MOUNTED TO. COATED WITH A BAKED ON POLYESTER POWDER COAT FINISH.

ALL HARDWARE IS NON-CORROSIVE.

WEIGHT FOR THE T46WEBINFS IS 303 LBS.

MAINTENANCE

To maintain luster it is recommended to wash, rinse, and dry the units after prolonged use. Check for loose bolts and nuts and tighten as needed. Contact the factory for genuine Webcoat part replacements if needed.