



T46WEBINNV-3SM

**3 SEAT WEB STYLE
INNOVATED PEDESTAL TABLE
SURFACE MOUNT DESIGN**

WEBCOAT PRODUCTS
P.O. BOX 3160
McALESTER, OKLAHOMA 74501
1-800-505-5101
FAX: (918)426-5924
E-MAIL: WEBCOAT@WEBCOAT.COM

Please take the time to locate and identify each part. Assemble the units on a smooth flat surface. It is also helpful to lay the tops and seats on cardboard or a drop cloth to prevent scratching of the surface during assembly. All parts have been pre-cut and pre-drilled for ease of assembly. All holes are slotted to allow for easy assembly and for final levelling of tops and seats to frames. Fully assemble all parts without totally tightening nuts and bolts. After all assembled go back and retighten nuts to bolts. DO NOT OVER TIGHTEN NUTS TO BOLTS. Over tightened nuts can crack the plastisol coating. All the necessary quantities of parts required are listed in this assembly instructions.

DO NOT BEGIN ASSEMBLY UNTIL YOU HAVE READ THESE INSTRUCTIONS AND ARE FAMILIAR WITH THE PARTS.



PARTS IDENTIFICATION

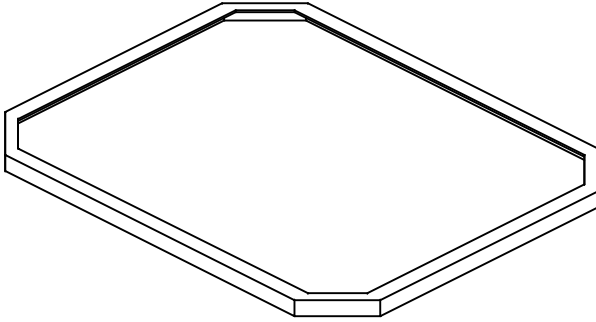

(A) 46" INNVDHCP TOP

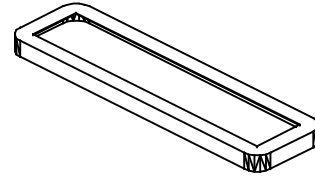

(B) 38" INNVD SEAT

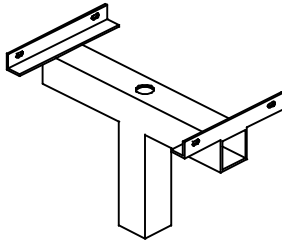

(C) CENTER POST

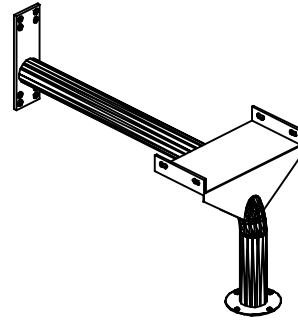

(D) PEDESTAL ARMS

PARTS LIST

ITEM	PART#	DESCRIPTION	QTY.
A	TT46INNVDHCP	46" INNVDHCP TOP	1
B	S38INNVD	38" INNVD SEAT	3
C	FWEBCP	CENTER POST	1
D	F46WEBARMSMP	PEDESTAL ARM WEB	3

ITEM	HARDWARE DESCRIPTION	QTY.
HW1	5/16" X 18 NYL LOCKNUTS	20
HW2	5/16" X 18GA CAP BOLTS	20
HW3	5/16" FLAT WASHERS	40
HW4	BOLT GUARDS	20
HW5	5/8" BOLTS	8
HW6	5/8" NUTS	8

ASSEMBLY TOOLS REQUIRED
2- 1/2" WRENCHES

HARDWARE IDENTIFICATION



(HW1) 5/16" X 18
NYL LOCKNUTS



(HW2) 5/16" X 18
GAUGE CAP BOLTS



(HW5) 5/8" NUTS



(HW3) 5/16"
FLAT WASHERS



(HW4) BOLT
GUARDS



(HW6) 5/8" BOLTS

ASSEMBLY PROCEDURES

STEP 1

BOLT THE ARMS TO THE CENTER POST USING EIGHT 5/8" BOLTS AND EIGHT 5/8" NUTS, Hand tighten at this time.

STEP 2

MOUNT THE SEATS BY MEANS OF FOUR 5/16" X 1 1/2" HEXBOLTS, EIGHT 5/16" FLAT WASHERS AND FOUR 5/16" NYLOCK NUTS, PER SEAT, THROUGH THE SLOTTED HOLES ON THE SEATS AND THROUGH THE SLOTTED HOLES ON ANGLE IRON OF FRAME ENDS.

Hand tighten only at this time.

STEP 3

ATTACH TABLE TO A SMOOTH LEVEL SURFACE.
SURFACE MOUNTING HARDWARE NOT INCLUDED.

STEP 4

TIGHTEN ALL NUTS ON ALL BOLTS AND PLACE THE BOLT GUARDS ON ALL NUTS. DO NOT OVER TIGHTEN THE NUTS AS THIS COULD CAUSE THE PLASTISOL COATING TO CRACK.

1	CAP BOLT & WASHER
2	WASHER & LOCK NUT

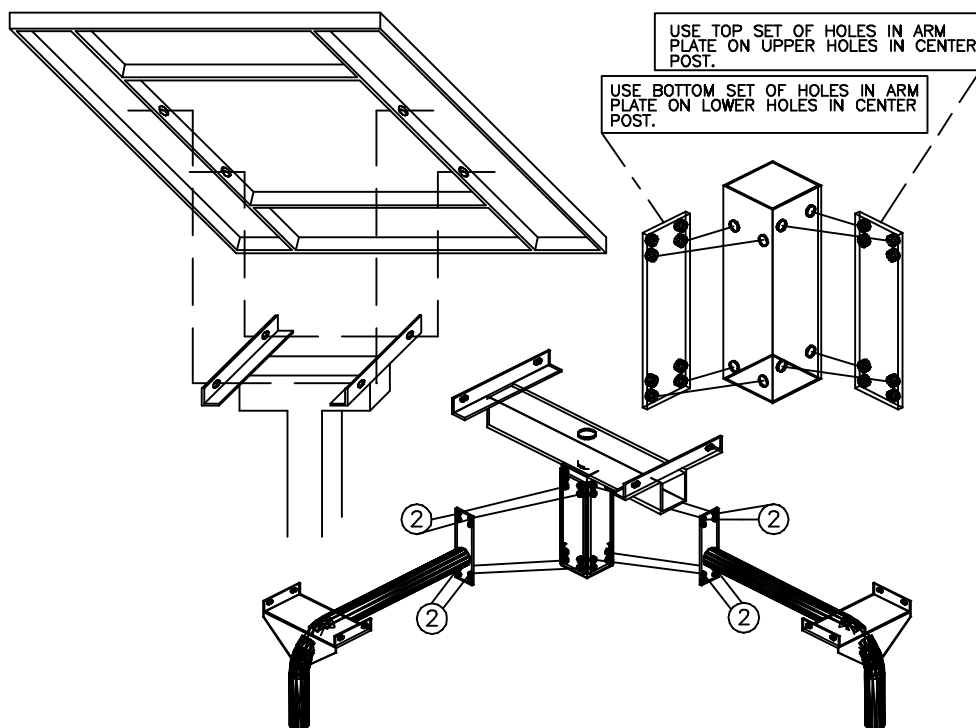

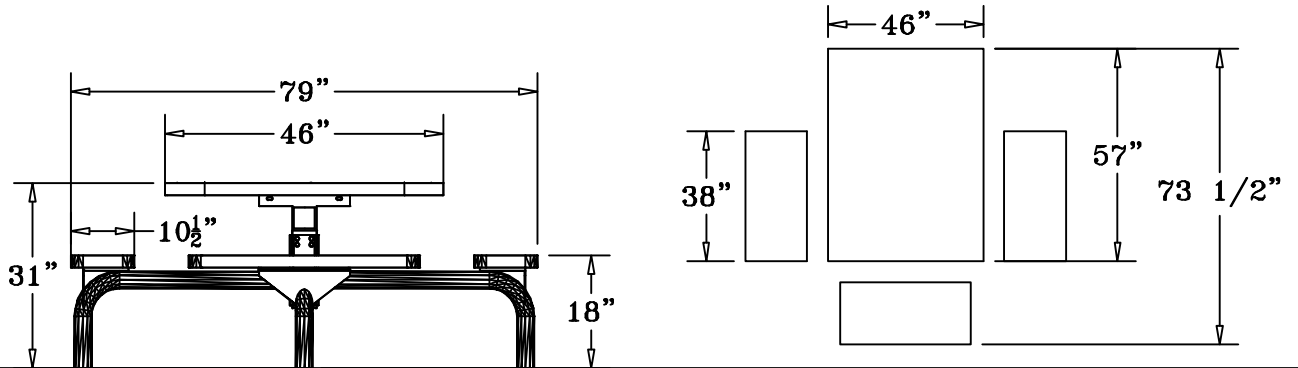

SPECIFICATIONS

46" PUNCHED STEEL TABLE WITH THREE ATTACHED 38" X 10 1/2" SEATS.
FRAME IS SURFACE MOUNT DESIGN.

COATED WITH A 1/8" TO 1/4" THICK PLASTISOL ULTRAVIOLET STABILIZED VINYL COATING FUSED
AND BAKED TO A 90% GLOSS.

TABLE HEIGHT IS 31" APPROXIMATELY. SEAT HEIGHT IS 18" APPROXIMATELY.
TOTAL OVERALL SQUARED DIMENSION IS 79" X 73 1/2" APPROXIMATELY.

TOP AND SEATS ARE MADE FROM 1/2" HOLE 11 GA. PRECISION PUNCHED STEEL INSIDE OF
A 2" X 2" X 1/8" ANGLE IRON FRAME.

FRAME IS A SINGLE 4" X 4" PEDESTAL MOUNTED TO THE CENTER OF THE TABLE TOP. EXTENDING
OUT FROM THE 4" SQUARE TUBING ARE THREE 2 7/8" ROUND TUBING ARMS THAT THE SEATS ARE
MOUNTED TO. COATED WITH A BAKED ON POLYESTER POWDER COAT FINISH.

ALL HARDWARE IS NON-CORROSIVE.

WEIGHT FOR THE T46WEBINNV-3SM IS 255 LBS.

MAINTENANCE

To maintain luster it is recommended to wash, rinse, and dry the units after prolonged use.
Check for loose bolts and nuts and tighten as needed. Contact the factory for genuine
Webcoat part replacements if needed.