



T7WEBINFINNV5

7' WEB INFINITY INNOVATED STYLE
SPLIT SEAT TABLE
INGROUND MOUNT DESIGN

WEBCOAT PRODUCTS
P.O. BOX 3160
McALESTER, OKLAHOMA 74501
1-800-505-5101
FAX: (918)426-5924
E-MAIL: WEBCOAT@WEBCOAT.COM

Please take the time to locate and identify each part. Assemble the units on a smooth flat surface. It is also helpful to lay the tops and seats on cardboard or a drop cloth to prevent scratching of the surface during assembly. All parts have been pre-cut and pre-drilled for ease of assembly. All holes are slotted to allow for easy assembly and for final levelling of tops and seats to frames. Fully assemble all parts without totally tightening nuts and bolts. After all assembled go back and retighten nuts to bolts. DO NOT OVER TIGHTEN NUTS TO BOLTS. Over tightened nuts can crack the plastisol coating. All the necessary quantities of parts required are listed in this assembly instructions.

DO NOT BEGIN ASSEMBLY UNTIL YOU HAVE READ THESE INSTRUCTIONS AND ARE FAMILIAR WITH THE PARTS.



PARTS IDENTIFICATION

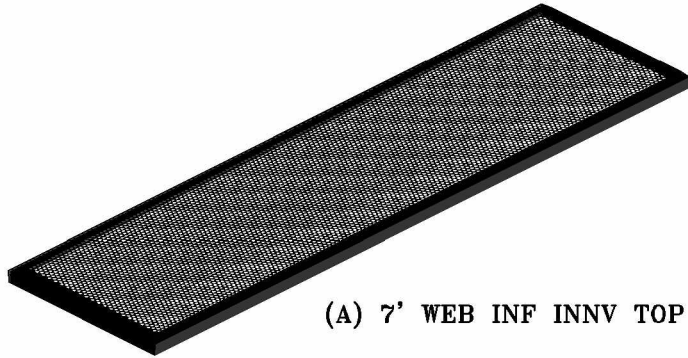

(A) 7' WEB INF INNV TOP



(B) 36" WEB INF INNV SEAT

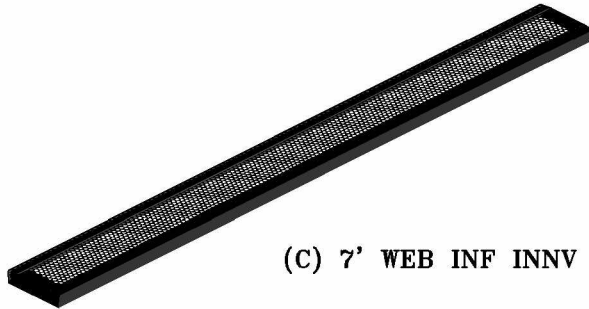

(C) 7' WEB INF INNV SEAT



(E) F9CPIPE

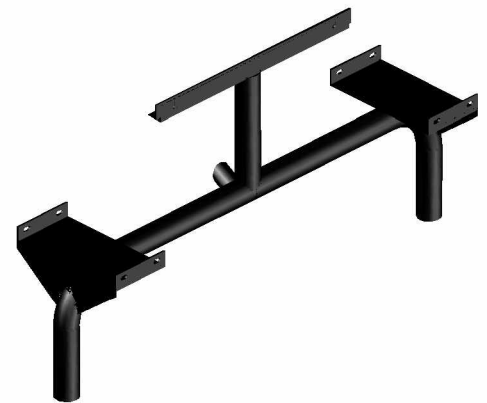

(D) WEB FRAME

PARTS LIST

ITEM	PART#	DESCRIPTION	QTY.
A	TT7INFINNV	7' INF INNV TOP	1
B	S36INFINNV	36" INF INNV SEAT	2
C	S7INFINNV	7' INF INNV SEAT	1
D	WEBFRAME	WEB FRAME	2
E	FCPIPE	CONNECTING PIPE	1

ITEM	HARDWARE DESCRIPTION	QTY.
HW1	5/16" X 18 NYL LOCKNUTS	16
HW2	5/16" X 18GA CAP BOLTS	16
HW3	5/16" FLAT WASHERS	32
HW4	BOLT GUARDS	16

ASSEMBLY TOOLS REQUIRED
2- 1/2" WRENCHES

HARDWARE IDENTIFICATION



(HW1) 5/16" X 18
NYL LOCKNUTS

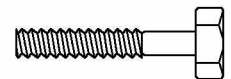

(HW2) 5/16" X 18
GAUGE CAP BOLTS



(HW3) 5/16"
FLAT WASHERS



(HW4) BOLT
GUARDS

ASSEMBLY PROCEDURES

STEP 1

LAY TOP UPSIDE DOWN ON A SMOOTH FLAT SURFACE. MOUNT ONE SET OF FRAMES TO EACH END OF TABLE, SQUARED TO THE TOP. TABS WELDED ON FRAMES FOR DIAGONALS MUST BE FACING EACH OTHER. ANGLE IRON ON FRAMES MUST BE BOLTED TO OUTSIDE OF BRACES ON TABLE TOP. FASTEN BY MEANS OF FOUR 5/16" X 1 1/2" CAP BOLTS, EIGHT 5/16" FLAT WASHERS AND FOUR 5/16" NYLOCK NUTS. HAND TIGHTEN ONLY AT THIS TIME.

STEP 2

CAREFULLY SET TABLE UPRIGHT.

STEP 3

SET 9' SEAT ON EITHER SIDE OF TABLE TOP MATCHING UP HOLES IN EACH SET OF SEAT BRACES WITH HOLES IN EACH OF THE SEAT BRACKETS ON FRAMES. Hand tighten only at this time.

STEP 4

SET EACH OF THE 36" SEATS ON OPPOSITE SIDE MATCHING UP HOLES IN EACH SET OF SEAT BRACES WITH HOLES IN EACH OF THE SEAT BRACKETS ON THE FRAMES. Hand tighten only at this time.

STEP 5

FOLLOWING THE FOOTING DIAGRAM BELOW, DIG FOUR INLINE HOLES APPROXIMATELY 24" DEEP BY 12" ROUND.

STEP 6

SET FRAMES IN HOLES. MAKE SURE TOP OF SEATS ARE 18" ABOVE GROUND LEVEL AND ARE IN LINE. FILL WITH CONCRETE.

LET STAND 24 HOURS BEFORE COMPLETING ASSEMBLY INSTRUCTIONS.

STEP 7

ALIGN AND LEVEL ALL PARTS AND TIGHTEN NUTS TO BOLTS.

DO NOT OVER TIGHTEN AS THIS WILL CAUSE THE PLASTISOL COATING TO CRACK.

1	CAP BOLT & WASHER
2	WASHER & LOCK NUT

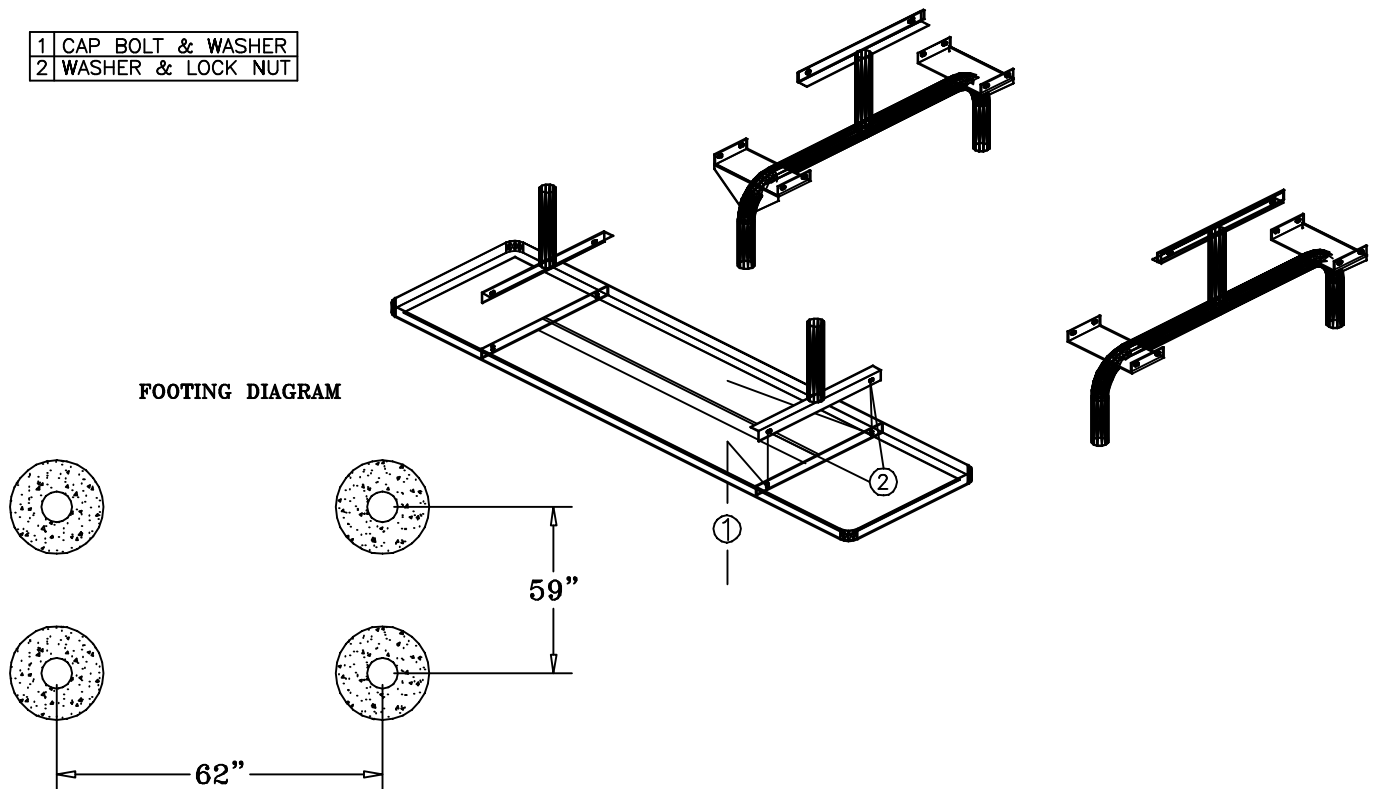

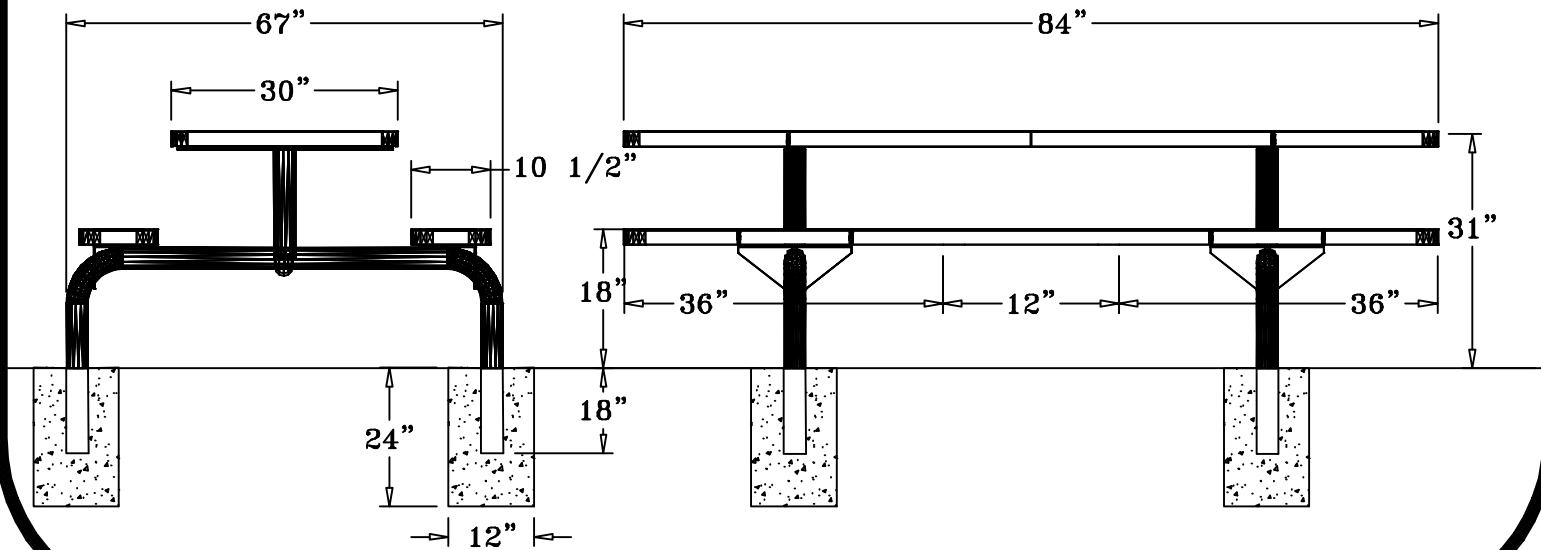

SPECIFICATIONS

7' POLY VINYL PUNCHED STEEL TABLE TOP WITH TWO ATTACHED 36" X 10 1/2" SEATS. AND 1 7' SEAT. ALL CORNERS ARE ROUNDED. THE FRAME IS INGROUND MOUNT DESIGN. TOP AND SEAT EDGES ARE SLOPED.

COATED WITH A 1/8" TO 1/4" THICK PLASTISOL ULTRAVIOLET STABILIZED VINYL COATING FUSED AND BAKED TO A 90% GLOSS.

TABLE HEIGHT IS 31" APPROXIMATELY. SEAT HEIGHT IS 18" APPROXIMATELY. TOTAL OVERALL DIMENSIONS ARE 84" X 67".

TOP AND SEATS ARE MADE FROM 1/2" HOLE 11 GA. PRECISION PUNCHED STEEL INSIDE OF A 2" X 2" X 1/8" ANGLE IRON FRAME. ALL CENTER BRACES ARE MADE FROM 1/4" X 1 1/2" FLAT STEEL.

FRAMES ARE MADE OF 2 7/8" HEAVY GALVANIZED STEEL TUBING THAT IS GALVANIZED INSIDE AND OUT AND MEETS OR EXCEEDS THE YIELD AND TENSILE OF SCH 40 PIPE. CONSTRUCTED SO AS TO PROHIBIT RAIN WATER FROM COLLECTING AT GROUND LEVEL. COATED WITH A BAKED ON POLYESTER POWDER COAT FINISH.

ALL HARDWARE IS NON-CORROSIVE

WEIGHT FOR THE T7WEBINFINNVS IS 336 LBS.

MAINTENANCE

To maintain luster it is recommended to wash, rinse, and dry the units after prolonged use. Check for loose bolts and nuts and tighten as needed. Contact the factory for genuine Webcoat part replacements if needed.