



T9WEBINFHDCPPSM

9' WEB INFINITY STYLE
SPLIT SEAT HANDICAP TABLE
PORTABLE OR SURFACE MOUNT DESIGN

WEBCOAT PRODUCTS
P.O. BOX 3160
McALESTER, OKLAHOMA 74501
1-800-505-5101
FAX: (918)426-5924
E-MAIL: WEBCOAT@WEBCOAT.COM

Please take the time to locate and identify each part. Assemble the units on a smooth flat surface. It is also helpful to lay the tops and seats on cardboard or a drop cloth to prevent scratching of the surface during assembly. All parts have been pre-cut and pre-drilled for ease of assembly. All holes are slotted to allow for easy assembly and for final levelling of tops and seats to frames. Fully assemble all parts without totally tightening nuts and bolts. After all assembled go back and retighten nuts to bolts. DO NOT OVER TIGHTEN NUTS TO BOLTS. Over tightened nuts can crack the plastisol coating. All the necessary quantities of parts required are listed in this assembly instructions.

DO NOT BEGIN ASSEMBLY UNTIL YOU HAVE READ THESE INSTRUCTIONS AND ARE FAMILIAR WITH THE PARTS.



PARTS IDENTIFICATION

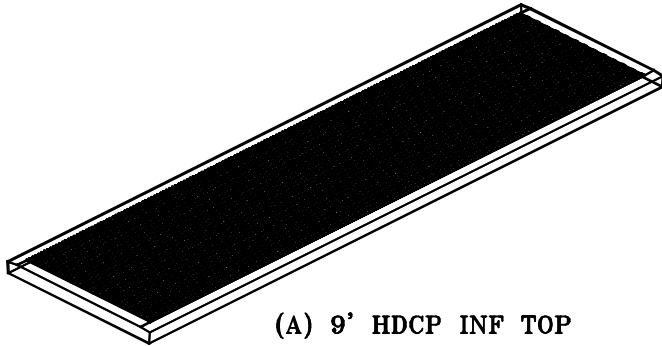

(A) 9' HDCP INF TOP

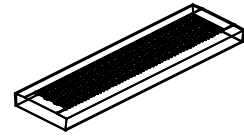

(B) 48" HDCP INF SEAT

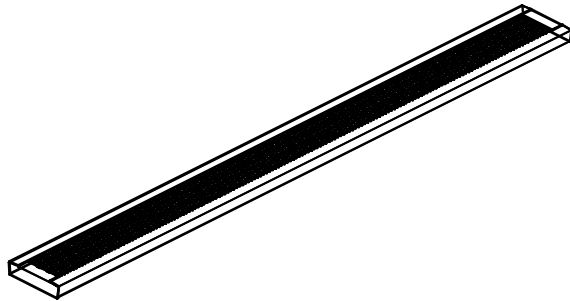

(C) 9' HDCP INF SEAT

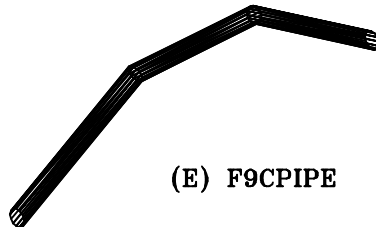

(E) F9CPIPE

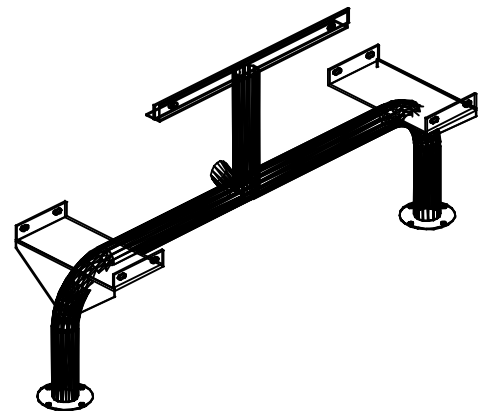

(D) WEB FRAME

PARTS LIST

ITEM	PART#	DESCRIPTION	QTY.
A	TT9INFHDCP	9' INF HDCP TOP	1
B	S36INFHDCP	36" INF HDCP SEAT	2
C	S9INFHDCP	9' INF HDCP SEAT	1
D	WEBFRAME	WEB FRAME	2
E	FCPIPE	CONNECTING PIPE	1

ITEM	HARDWARE DESCRIPTION	QTY.
HW1	5/16" X 18 NYL LOCKNUTS	16
HW2	5/16" X 18GA CAP BOLTS	16
HW3	5/16" FLAT WASHERS	32
HW4	BOLT GUARDS	16

ASSEMBLY TOOLS REQUIRED
2- 1/2" WRENCHES

HARDWARE IDENTIFICATION



(HW1) 5/16" X 18 NYL LOCKNUTS

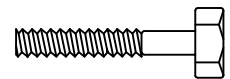

(HW2) 5/16" X 18 GAUGE CAP BOLTS



(HW3) 5/16" FLAT WASHERS



(HW4) BOLT GUARDS

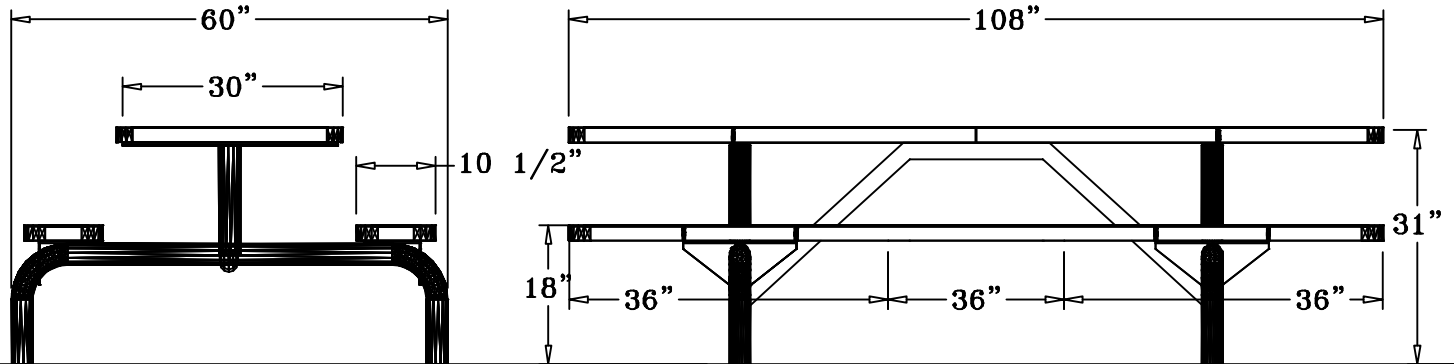

SPECIFICATIONS

9' POLY VINYL EXPANDED METAL TABLE TOP WITH TWO ATTACHED 36" X 10 1/2" SEATS. AND 1 9' SEAT. ALL CORNERS ARE ROUNDED. THE FRAME IS PORTABLE SURFACE MOUNT DESIGN. TOP AND SEAT EDGES ARE SLOPED.

COATED WITH A 1/8" TO 1/4" THICK PLASTISOL ULTRAVIOLET STABILIZED VINYL COATING FUSED AND BAKED TO A 90% GLOSS.

TABLE HEIGHT IS 31" APPROXIMATELY, SEAT HEIGHT IS 18" APPROXIMATELY. TOTAL OVERALL DIMENSIONS ARE 108" X 67".

TOP AND SEATS ARE MADE WITH HEAVY DUTY 3/4" #9 EXPANDED METAL INSIDE OF A 2" X 2" X 1/8" ANGLE IRON FRAME. ALL CENTER BRACES ARE MADE FROM 1/4" X 1 1/2" FLAT STEEL.

FRAMES ARE MADE OF 2 7/8" HEAVY GALVANIZED STEEL TUBING THAT IS GALVANIZED INSIDE AND OUT AND MEETS OR EXCEEDS THE YIELD AND TENSILE OF SCH 40 PIPE. CONSTRUCTED SO AS TO PROHIBIT RAIN WATER FROM COLLECTING AT GROUND LEVEL. COATED WITH A BAKED ON POLYESTER POWDER COAT FINISH.

ALL HARDWARE IS NON-CORROSIVE

WEIGHT FOR THE T9WEBINFHDCPPSM IS 311 LBS.

MAINTENANCE

To maintain luster it is recommended to wash, rinse, and dry the units after prolonged use. Check for loose bolts and nuts and tighten as needed. Contact the factory for genuine Webcoat part replacements if needed.