



TS46WEBRACS-2SM

**46" ROUND WEB STYLE
2 SEAT SOLID TOP TABLE
SURFACE MOUNT DESIGN**

WEBCOAT PRODUCTS
P.O. BOX 3160
McALESTER, OKLAHOMA 74501
1-800-505-5101
FAX: (918)426-5924
E-MAIL: WEBCOAT@WEBCOAT.COM

Please take the time to locate and identify each part. Assemble the units on a smooth flat surface. It is also helpful to lay the tops and seats on cardboard or a drop cloth to prevent scratching of the surface during assembly. All parts have been pre-cut and pre-drilled for ease of assembly. All holes are slotted to allow for easy assembly and for final levelling of tops and seats to frames. Fully assemble all parts without totally tightening nuts and bolts. After all assembled go back and retighten nuts to bolts. DO NOT OVER TIGHTEN NUTS TO BOLTS. Over tightened nuts can crack the plastisol coating. All the necessary quantities of parts required are listed in this assembly instructions.

DO NOT BEGIN ASSEMBLY UNTIL YOU HAVE READ THESE INSTRUCTIONS AND ARE FAMILIAR WITH THE PARTS.



PARTS IDENTIFICATION

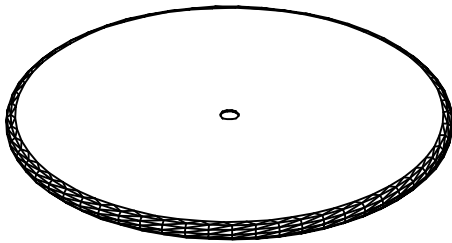

(A) 46" ROUND SOLID TOP

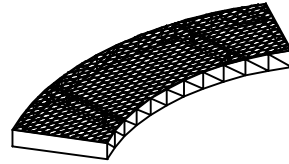

(B) 38" CONCAVE SEAT

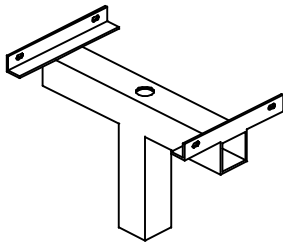

(C) CENTER POST

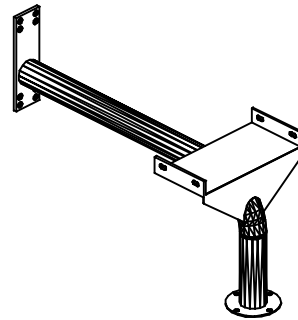

(D) PEDESTAL ARMS

PARTS LIST

ITEM	PART#	DESCRIPTION	QTY.
A	TTS46RACS	46" ROUND SOLID TOP	1
B	S38RACS	38" CONCAVE SEAT	2
C	F46PEDCP	CENTER POST	1
D	F46WEBARMSM	PEDESTAL ARM WEB	2

ITEM	HARDWARE DESCRIPTION	QTY.
HW1	5/16" X 18 NYL LOCKNUTS	16
HW2	5/16" X 18GA CAP BOLTS	16
HW3	5/16" FLAT WASHERS	32
HW4	BOLT GUARDS	16
HW5	5/8" BOLTS	4
HW6	5/8" NUTS	4

ASSEMBLY TOOLS REQUIRED
2- 1/2" WRENCHES

HARDWARE IDENTIFICATION



(HW1) 5/16" X 18
NYL LOCKNUTS



(HW2) 5/16" X 18
GAUGE CAP BOLTS



(HW5) 5/8" NUTS



(HW3) 5/16"
FLAT WASHERS



(HW4) BOLT
GUARDS



(HW6) 5/8" BOLTS

ASSEMBLY PROCEDURES

STEP 1

SET TABLE TOP ON TOP OF THE TABLE POSTS MATCHING THE HOLES IN THE CROSS BRACES OF TOP WITH HOLES IN THE ANGLE IRON BRACES OF THE TABLE POSTS. MOUNT BY MEANS OF FOUR 5/16" X 1 1/2" CAP BOLTS, EIGHT 5/16" FLAT WASHERS, AND FOUR 5/16" NYLOCK NUTS.

STEP 2

SET SEATS ON TOP OF THE SEAT POSTS MATCHING THE HOLES IN THE CROSS BRACES OF SEAT WITH HOLES IN THE ANGLE IRON BRACES OF THE SEAT POSTS. MOUNT BY MEANS OF FOUR 5/16" X 1 1/2" CAP BOLTS, EIGHT 5/16" FLAT WASHERS, AND FOUR 5/16" NYLOCK NUTS PER SEAT.

STEP 3

MOUNT TABLE TO A SMOOTH LEVEL SURFACE.
SURFACE MOUNTING HARDWARE NOT INCLUDED.

STEP 4

TIGHTEN ALL NUTS ON BOLTS AND PLACE BOLT GUARDS ON ALL NUTS. DO NOT OVER TIGHTEN AS THIS COULD CAUSE THE PLASTISOL COATING TO CRACK.

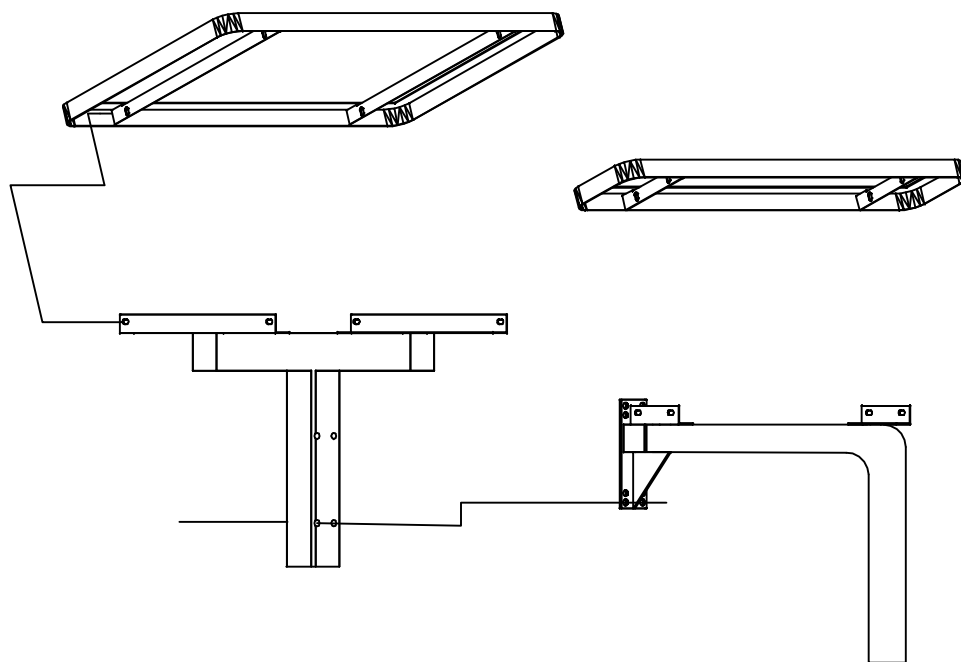

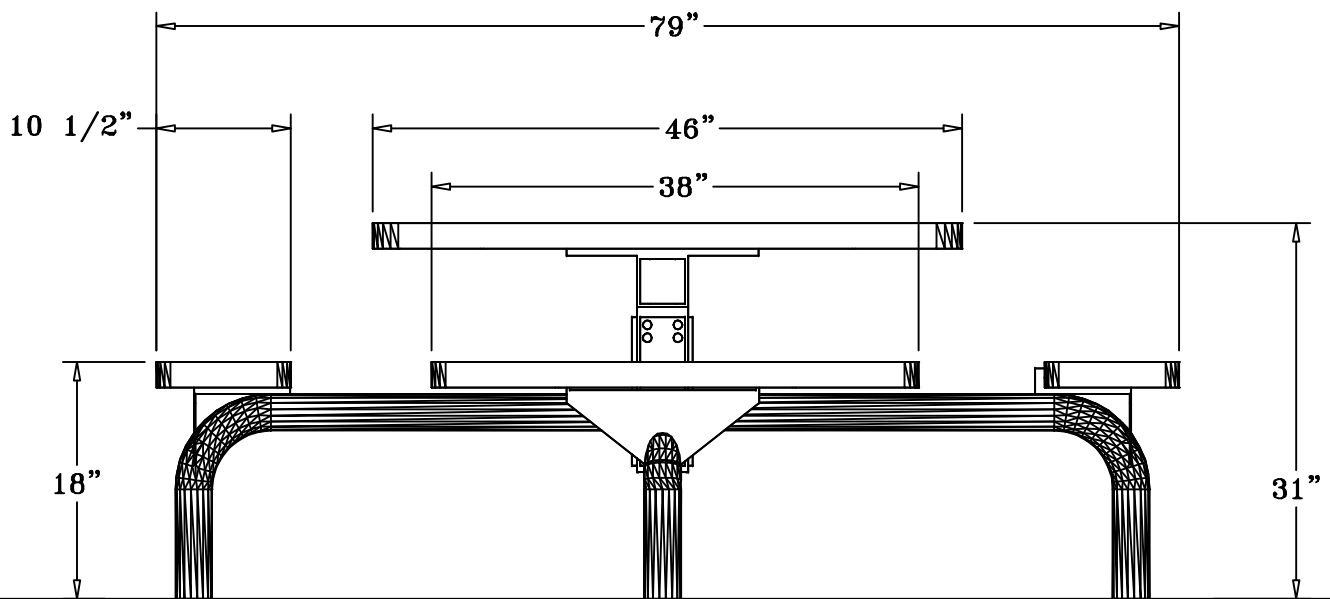

SPECIFICATIONS

46" ROUND SOLID TOP TABLE WITH THREE ATTACHED 38" X 10 1/2" CONCAVE SEATS. FRAME IS SURFACE MOUNT DESIGN.

COATED WITH A 1/8" TO 1/4" THICK PLASTISOL ULTRAVIOLET STABILIZED VINYL COATING FUSED AND BAKED TO A 90% GLOSS.

TABLE HEIGHT IS 31" APPROXIMATELY. SEAT HEIGHT IS 18" APPROXIMATELY. TOTAL OVERALL SQUARED DIMENSION IS 79" APPROXIMATELY.

TOP AND SEATS ARE MADE WITH HEAVY DUTY 3/4" #9 EXPANDED METAL INSIDE OF A 2" X 2" X 1/8" ANGLE IRON FRAME.

FRAME IS A SINGLE 4" X 4" PEDESTAL MOUNTED TO THE CENTER OF THE TABLE TOP. EXTENDING OUT FROM THE 4" SQUARE TUBING ARE THREE 2 7/8" ROUND TUBING ARMS THAT THE SEATS ARE MOUNTED TO. COATED WITH A BAKED ON POLYESTER POWDER COAT FINISH.

ALL HARDWARE IS NON-CORROSIVE.

WEIGHT FOR THE TS46WEBRACS-3SM IS 213 LBS.

MAINTENANCE

To maintain luster it is recommended to wash, rinse, and dry the units after prolonged use. Check for loose bolts and nuts and tighten as needed. Contact the factory for genuine Webcoat part replacements if needed.